

CONTENTS

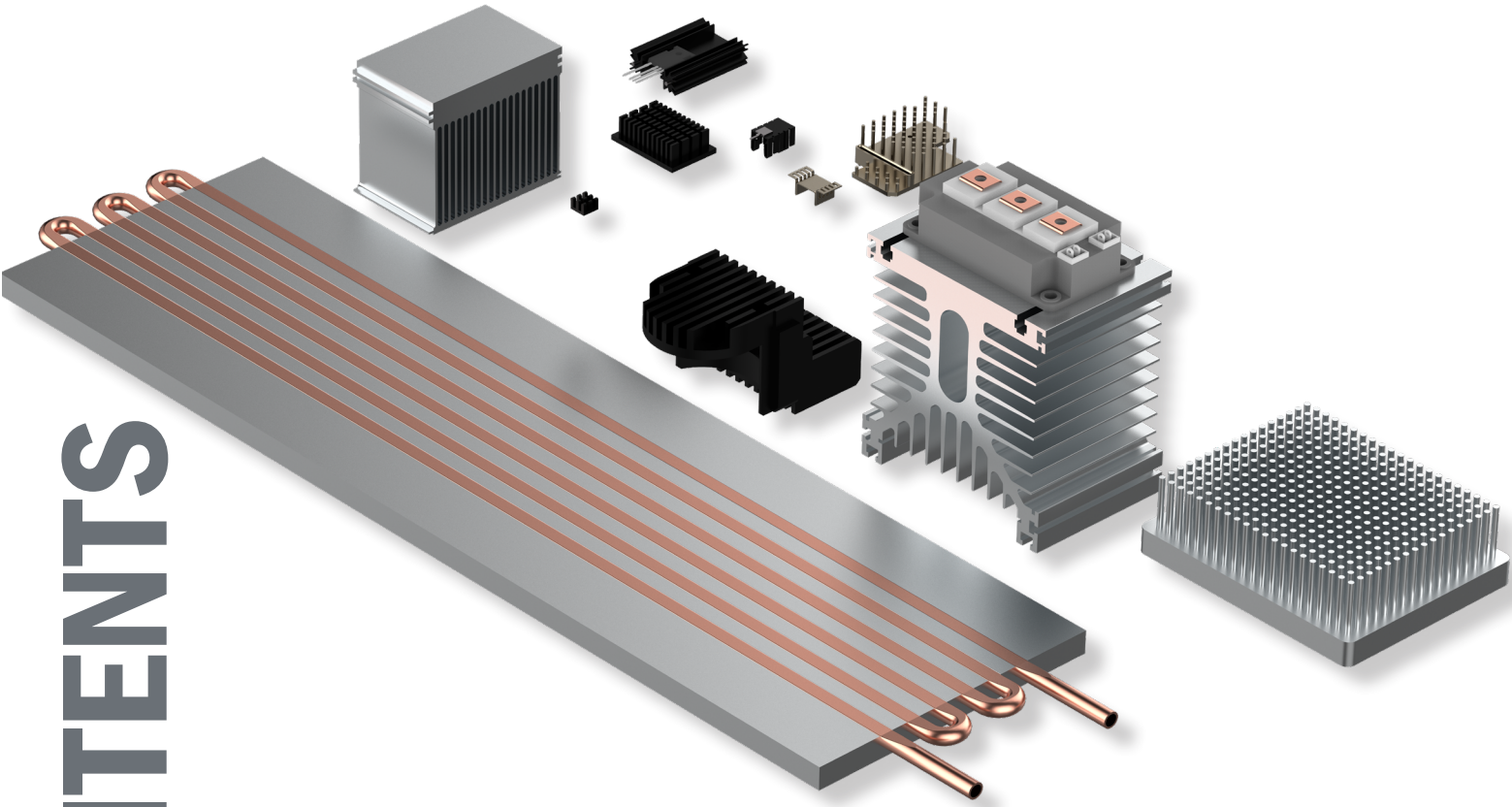

THERMAL SOLUTIONS

热方案设计 - 散热产品制造商

- Electric Vehicles [新能源汽车充电桩]
- Renewable Energies [风能 / 太阳能逆变器]
- Power Supply [大功率电源 / 低压电力]
- Medical Equipments [医疗器械设备]
- LED Lights [LED 商用照明]
- Embedded System [嵌入式工控]

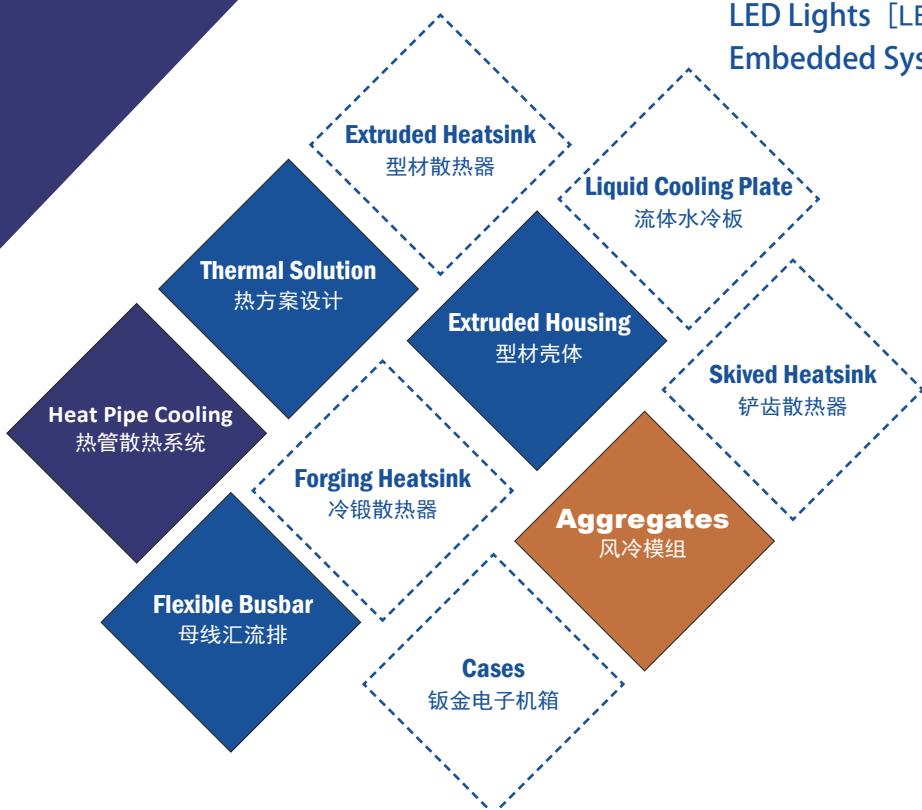



About +

仁信精工实业有限公司致力于为客户提供先进的散热解决方案。累积十多年的研发与技术投入，致力于不断的开发新产品来推动电子传热散热领域的技术发展。公司成立十二周年以来，以不断迭代的热方案设计与生产制造以及国际主要区域的销售网络，已经成为行业内领先的电子产品热方案提供商之一。

核心优势：



1. 设计 [CAD/CAE/CAM]：采用行业内最先进的散热设计理念，结合工程领域 CAD/CAE/CFD 技术和材料科学，表面处理技术等确保电子设备在高负荷工况运行下能够保持稳定的温升和温差控制。为设备的功能稳定性和可靠性提供专业的技术服务。



2. CAM 制造：不断更新和投入新型设备和应用新材料和新工艺来提升产品的生产周期与质量。通过 CAM 技术的应用，从 CAD 模型到小批量样品到批量生产，我们能够更快速地将概念到产品的生产制造，从而确保客户的项目研发进度与效率的竞争力。



3. 定制化服务：工业领域客户的需求各不相同，提供专业的定制化解决方案，从产品的概念设计到迭代优化到样品测试及批量生产。我们从实验室到生产车间制造到出货全流程的给客户提供可视化的定制服务和数据共享。



4. 可持续发展：积极响应客户供应链综合竞争力的经营理念，致力于开发可持续的电子散热技术。通过优化设计和材料选型为客户提高竞争力，同时自身努力降低产品的能耗和对环境的影响，为清洁能源和绿色生产做出贡献。





发展理念

贴近客户、解决客户的需求是我们发展的动力。仁信精工作为散热领域先进的提供商之一，先进设计理念与智能制造是我们的两个，来我们将以智能制造为焦点、给客户提定制化服务为制高点，为所有客户提供定制化可靠的热方案和优质产品是我们的理念。



管理理念

卓越的公司一定是优秀的团队，优秀的团队一定是聚集着一群优秀的人。公司的发展理念与规则管理与个人的发展与需求保持一至时，团队就是公司的竞争力，制度与规则也就成了团队与个人的利益共同发展坚实的保障。

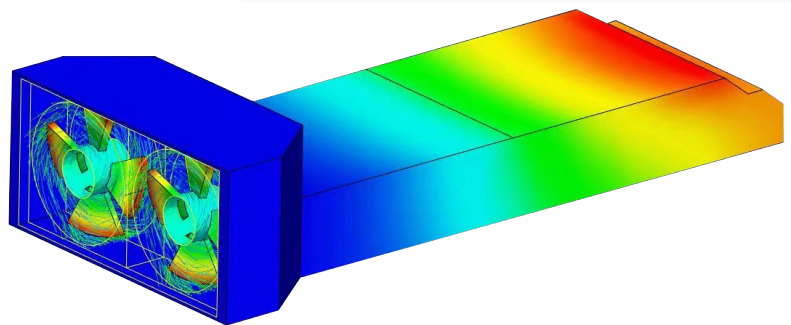
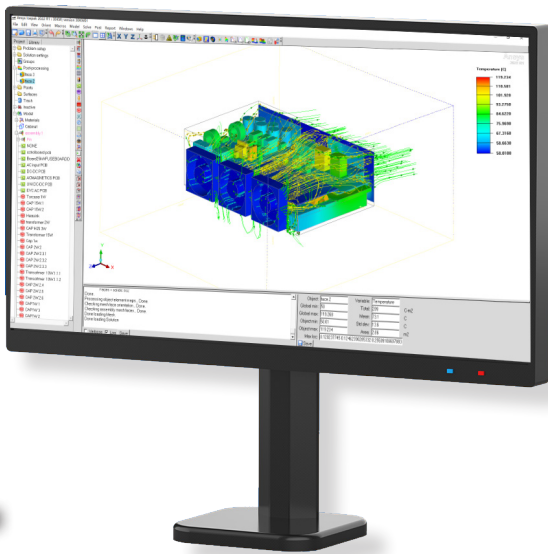

设计流程

专业的技术团队，利用 CAE/CFD 流体、传热、电磁、CAD 结构设计等最新的设计理念提供最优的方案。我们有专业的热实验室和测试实验室。能模拟多物理场的强迫空气流体冷却、自然对流冷却、专业风洞测试、热阻测试、高低温等各物理场的实验与测试





质量管理

所有作业、记录、流程、发布都按 ISO9001:2015 标准来执行，产品的质量管控来自完善的制造工艺和制造流程，从原材料来料检验到制程检验以及所有出货的产品经过全部测试。优良的产品质量既要符合标准才能给客户 提供竞争力，同时确保有两套方案满足客户不同需求。

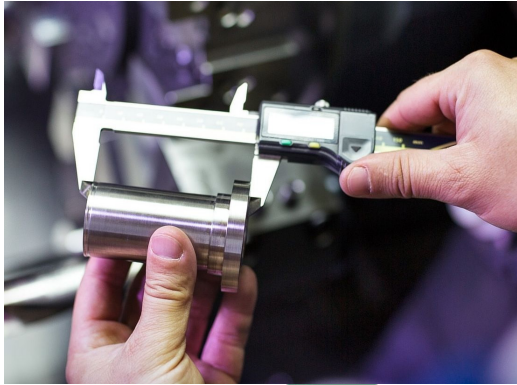

CERTIFICATE



ISO 9001:2015

DEKRA Certification GmbH hereby certifies that the organization

Renxin-Seiko Industry Co., Ltd.

1st Floor, 30 Weijian Road, Zone E, Weijian Industrial Park, Chashan Town, Dongguan City, Guangdong Province, 523385 China

for the scope of certification:

Manufacture and assembly for heatsinks, mounting parts and cases.

has established and maintains a quality management system according to the above mentioned standard. The conformity was adduced with audit report no. OF24010040.

Certificate registration no.:	30117012/3C
Validity of previous certificate:	2024-05-03
Certificate valid from:	2024-05-04
Certificate valid to:	2024-04-08
Most recent update:	2024-04-06



Dr. Rolf Krökel
DEKRA Certification GmbH, Stuttgart, 2024-04-06

DEKRA Certification GmbH * Handwerkstraße 15 * D-70565 Stuttgart * www.dekra-certification.de

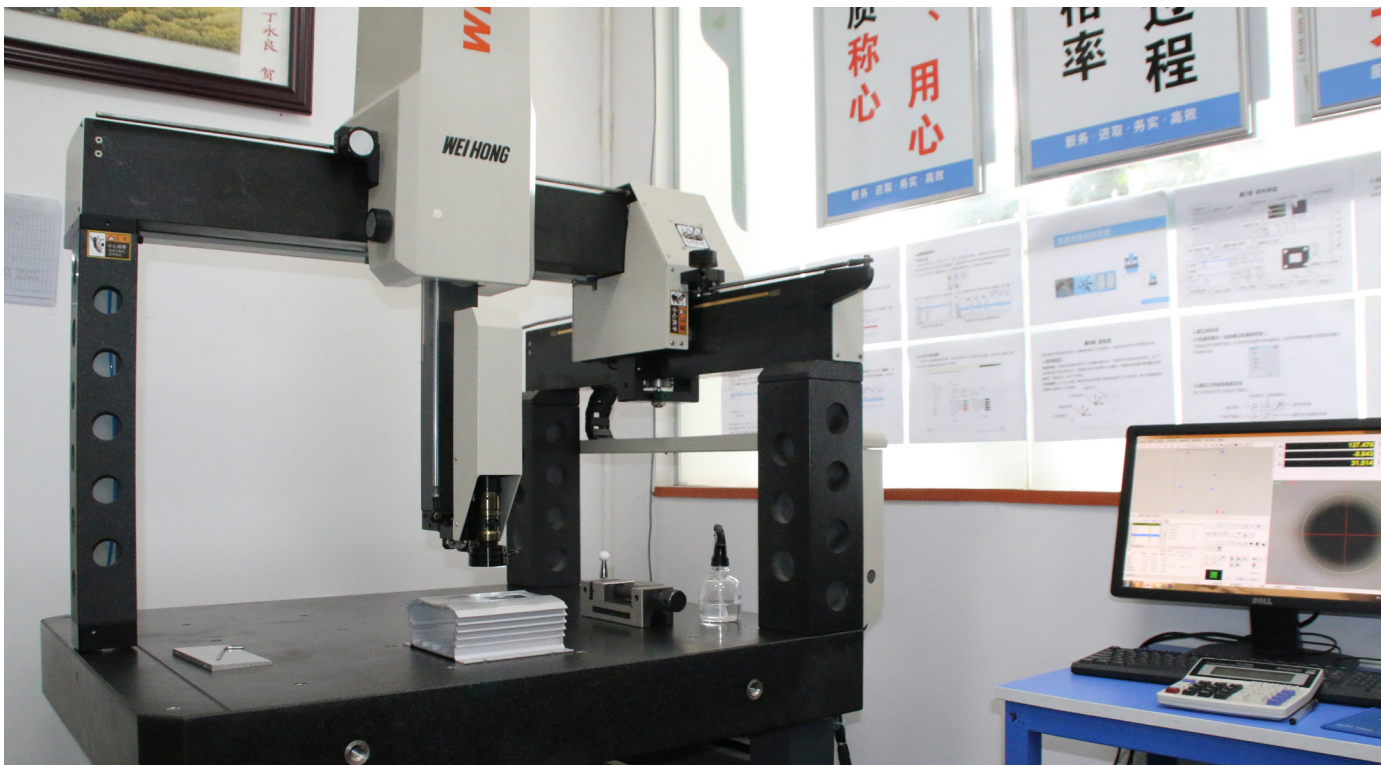

Dong Guan [东莞]

东莞市仁信精工实业有限公司

Renxin-Seiko Industry Co., Ltd

TEL: + 86 769 8182 2157/ 8182 2158 /8182 2159 FAX: + 86 769 8182 21576

地址：广东省东莞市茶山镇伟建工业区伟建路 E 区 30 号

#30 Weijian Road, Zone E, Weijian Industrial Park, Chashan Town, Dongguan City, Guangdong Province, China

website: www.renxin-precision.com

E_mail: info@renxin-precision.com

Hong Kong [香港]

仁信精工（香港）有限公司

Renxin Seiko (Hong Kong) Limited

TEL: + 00852 2139 3217 FAX: + 00852 2139 3219

地址：香港干诺道中 137-139 号三台大厦 12 字楼全层

12/F San Toi Building 137-139 Connaught Road Central Hongkong

Thailand [泰国]

仁信精工（泰国）有限公司

Renxin Seiko (Thailand) Limited

TEL: +66 (0) 96 0605 916

Address :95/18 Bang Bua Thong, Bang Bua Thong District, Nonthaburi 11110, Thailand

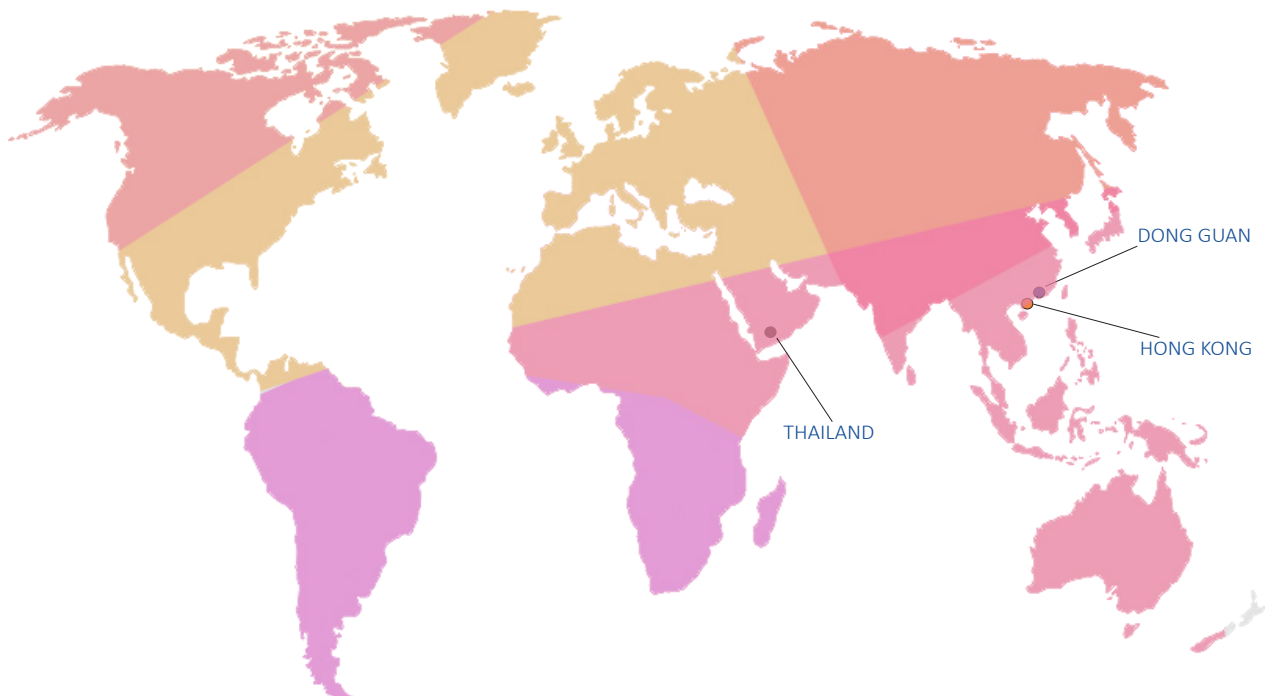

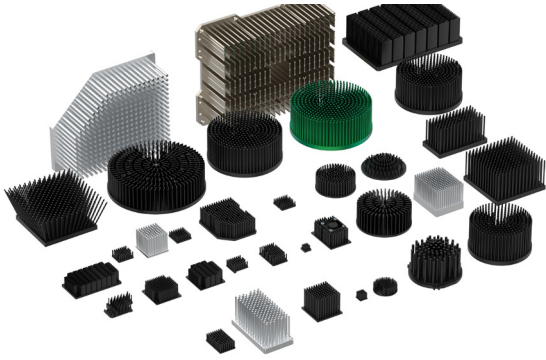

Forging Pin Heatsink
锻造工艺散热器

- ✘ AL1050[99.5%] / AL1070[99.7%] Forging Heatsink 冷锻散热器
- ✘ Pin-Fin Heat sink for 45 ~ 130 W COB LED Lights LED 植物生长照明
- ✘ Aluminum / Copper Forging + CNC Machining Heat sink
- ✘ DC Fan + Heatsink Cooling Module
- ✘ C1100 Copper / AL6063/ AL 4041 / AL 5052 - 水冷板扰流结构冷板

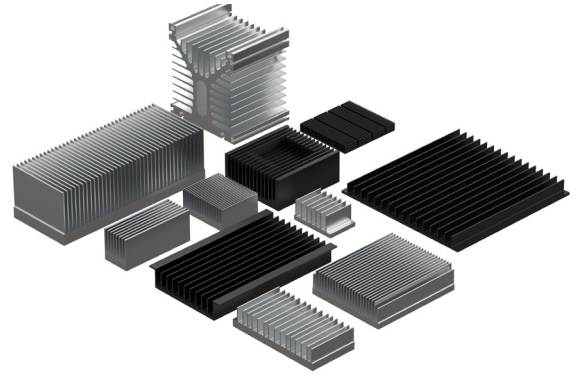

Extruded Profiles Heatsink
挤压型材散热器

- ✘ AL6063 - T5 Extruded Profiles for Aluminum
- ✘ Standard Extruded Heatsink 标准挤压型材散热器
- ✘ Customer specific special design 定制化型材散热器
- ✘ CNC Machining Heatsink 机械加工散热器
- ✘ Surface refinements 定制化表面处理

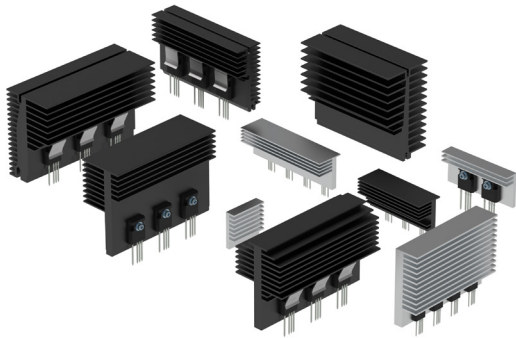

Max Clip system Extruded Heat sink
晶体管带弹夹安装固定散热器

- ✘ Heatsinks for PCB 挤压型材板级散热片
- ✘ Lock-in transistor fixing spring 板级散热片
- ✘ Extruded heatsinks for DC/DC converter 功率电源 DC/DC
- ✘ Heatsinks for lock-in retaining spring 快捷安装带弹夹散热片



Extruded Profiles Cases
挤压型材壳体和带散热翅片壳体

- ✘ Cooling Fin cases 挤压壳体带散热 Fin 散热壳体
- ✘ Combination Cases 抽拔式标准机箱壳体
- ✘ Miniature aluminium cases 迷你型壳体
- ✘ Shell cases 19" 寸标准化模块散热机箱
- ✘ Sheet metal forming [钣金机箱机柜]

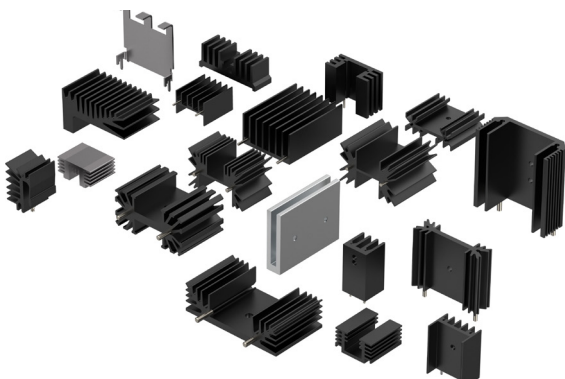

Extruded heatsinks with solder pins
板级散热器带焊接 Pin

- ✘ TO - 218/247/220/TO-3P 系列带焊接 Pin 散热片
- ✘ Aluminium flat-, quadrangular-, angled-, U- & T-profiles
- ✘ Attachable heatsinks 连接型散热器

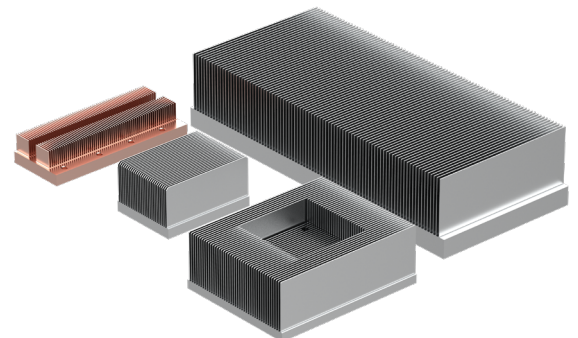

Skived Heatsink
铲齿散热器

- ✘ Skived Heatsink for Electric Vehicles [应用于充电桩铲齿散热器]
- ✘ Skived Fin Heatsink with Heat Pipe aggregates [铲齿散热器加热管]
- ✘ Special design Skived Heatsink [特殊设计铲片式散热器]



Cooling Aggregates
强迫风冷散热散模组

- ※ 100 ~ 200 W 适用于 30 ~ 50mm 直流风扇散热模组
- ※ 220 ~ 350W 适用于 40 ~ 50mm 直流风扇双通道散热模组
- ※ 0.5 kW ~ 1KW 适用于 90 mm 直流风扇大功率散热模组
- ※ 1.2 kW ~ 2KW 适用于 120 ~ 127 mm 直流风扇大功率散热模组

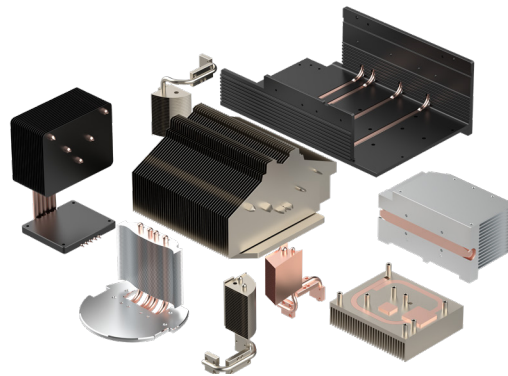

Heat Pipe Cooling System
热管散热器

- ※ Standard Heat Pipe $\Phi 6 \sim 10\text{mm}$ 标准热管散热器
- ※ Customer specific special design Heat Pipe + Fin 定制热管与结构方案
- ※ Low temperature Heat Pipe 超低温工况加氮气型热管散热系统
- ※ Micro Heat Pipe + DC Fan 微型热管带风扇散热模组

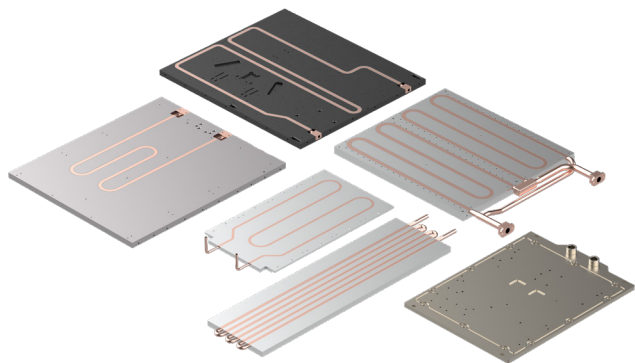

Fluid Coolers
流体冷板

- ※ Extruded Cooling Channel 挤压流道冷板
- ※ Embedded Copper Cooling Channel 布铜管冷板
- ※ Embedded Stainless steel cooling channel 不锈钢流道耐腐蚀冷板
- ※ FSW[friction stir welding] 摩擦焊流道水冷板

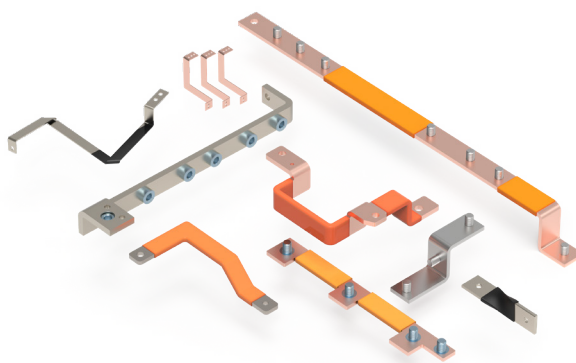

Multilayer Bus-Bar /flexible Busbar
汇流排 \ 多层软连接母排

- ※ Copper Stamp[CNC] Thickness 4 ~ 12mm Busbar 厚铜排 4~12mm
- ※ Multilayer copper rail bent with flexible connections 软连接
- ※ Advanced Insulated Braided Conductor 编织铜软连接带绝缘



Metal Stamping and Bending
钣金冲压折弯金属成型

- ※ Metal Stamping 钣金与冲压产品
- ※ Customer specifications parts 定制薄片金属成型产品
- ※ Customised 19" system case Rack Case 19" 电子机箱



Accessories
配件、压铸件、热界面导热材料

- ※ Connecting fittings [Fluid Coolers] 冷板附属配件
- ※ Die casting 铝合金压铸产品
- ※ Al_2O_3 -ceramics oxide wafers 氧化铝导热片 /TIM
- ※ Insulating spacers with internal and external thread 六角间隔柱

Cold- Forging Heatsink 冷锻散热系列

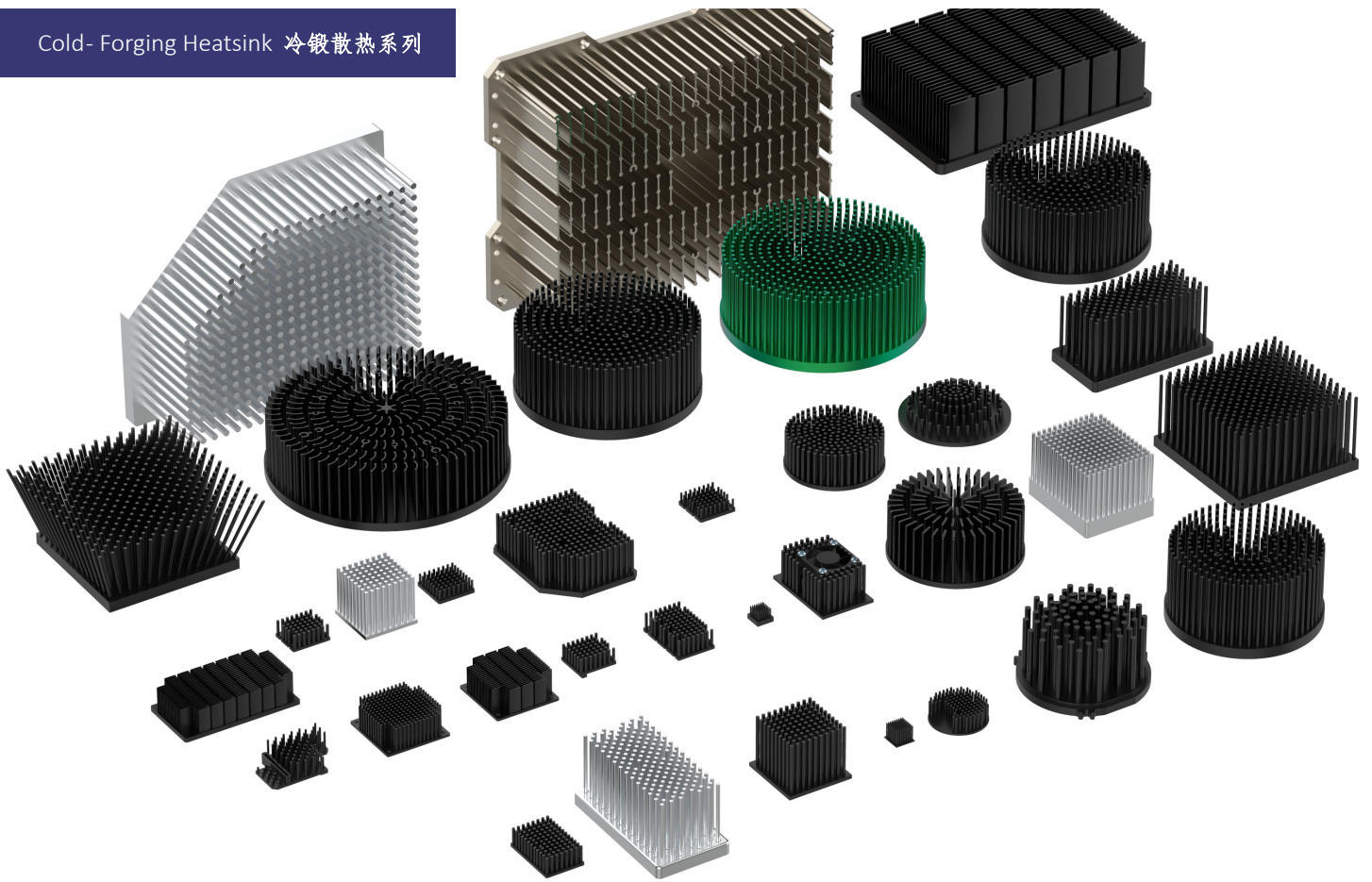

冷锻散热器是一种通过金属的塑性特点，在常温下对金属（铝 / 铜）施加压力以改变其可控形状的加工方法。与热锻相比，冷锻具有成本低、生产效率高以及成品品质优良等优点。冷锻散热片的成型原理和工艺流程，包括原材料选择、模具设计、成形加工、坯料后处理等环节。冷锻工艺参数通过 CAE 技术利用有限元法，有限差分法等将冷锻过程中的力学非线性问题进行仿真计算进行模拟，以提前发现设计缺陷。通过对模具的设计与优化、模具材料的选择以及质量控制等工艺技术，以提高冷锻件的成形质量和生产效率。冷锻工艺在新能源汽车、航空航天、电子散热、机械设备等领域有着广泛应用。

特点：

- 冷锻散热器一般选用纯铝 AL1050[99.5%] / AL1070[99.7%] 材质，其导热率在 220 ~ 235 W/M·K
- PIN 采用圆形设计，通过矩阵式排列在自然冷却的条件下可以有有效的减小气流阻力提升换热系数
- 基板与 PIN 的一体成型，可以有有效的恒定散热，不存在接触热阻。
- 灵活的安装方式可以采用导热胶粘合或 Push Pin 进行安装

Forging Pin Fin heatsink with DC Fan Cooling System

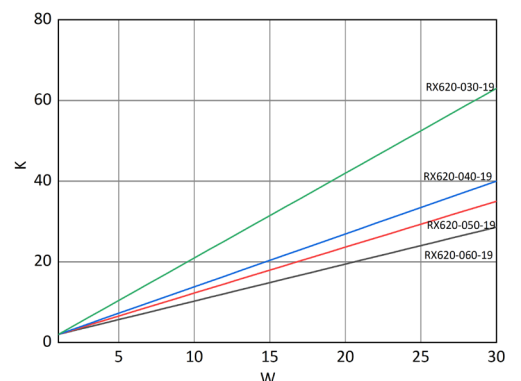
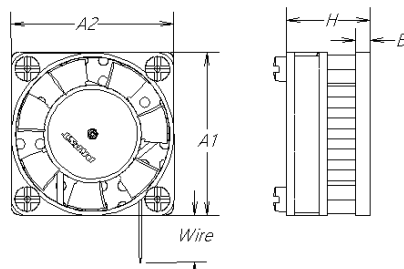
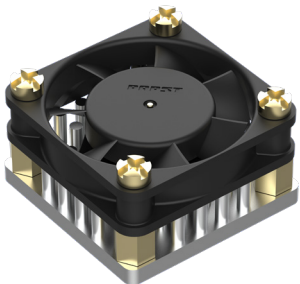

art no	RX620-030-19	RX620-040-19	RX620-050-19	RX620-060-19
A1 [mm]	30	40	50	60
A2 [mm]	30	40	50	60
H [mm]	16.5	20.5	32	37.6
B [mm]	3.5	3.5	4	4
operating voltage	4.5 ~ 5.5	4.5 ~ 5.5	10.8 ~ 13.2	10.8 ~ 13.2
Power consumption W	0.6	0.7	0.9	1
operating temperature	-20 ~ 85°C	-20 ~ 85°C	-20 ~ 85°C	-20 ~ 85°C
Air flow in m ³ /h	9.35	8	20	29
thermal resistance	2.1 K/W	1.42 K/W	1.12 K/W	0.62 K/W
Speed in min-1	1100	5400	5000	3900
Bearing system	Vapo bearing	Sintec sleeve bearing	Sintec sleeve bearing	Sintec sleeve bearing
Typ noise dB(A)	23	22.1	30	27
Service life L10 at 25 °C	60000 h	45000 h	50000 h	50000 h

Round OD 60 ~ 180 mm Forging Pin Fin heat sink

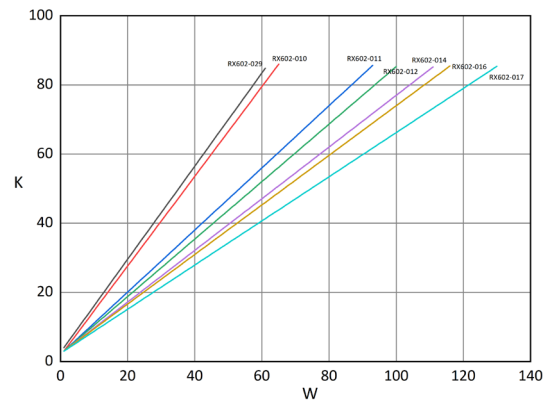
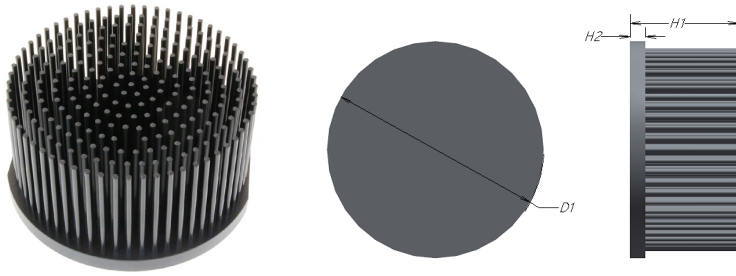

art no	RX602-010-A4	RX602-011-A4	RX602-012-A4	RX602-014-A4	RX602-016-A4	RX602-017-A4	RX602-029-A4
D [mm]	120	133	140	150	163	180	87
H1 [mm]	70	70	70	70	70	70	34
H2 [mm]	10	10	10	10	10	10	4
Pin-diameter	3	3	3	3	3	3	3
Pin - Count	197	253	240	316	386	441	193
material	AL1050[99.5%]	AL1050[99.5%]	AL1050[99.5%]	AL1050[99.5%]	AL1050[99.5%]	AL1050[99.5%]	AL1050[99.5%]
Finish	ANODIZE BLACK	anodize black	anodize black	anodize black	anodize black	anodize black	anodize black
Weight [kg]	0.54 KG	0.684 kg	0.728kg	0.862 kg	1.015 kg	1.251 kg	0.182 kg

Square W 15.8 ~ W 125 mm Forging Pin Fin heat sink

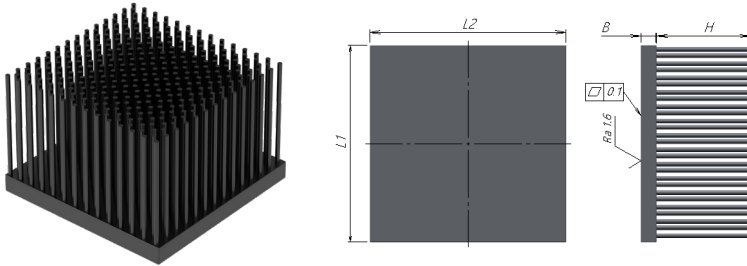

art no	RX602-018-A4	RX602-008-A1	RX602-009-A	RX602-050-A1
L1 [mm]	125	50	60	15.8
L2 [mm]	125	50	60	15.8
H [mm]	70	45	45	12.2
B [mm]	10	3.5	3.5	4.5
Pin-diameter	3	3	3	1
Pin- Count	365	81	96	49
material	AL1050[99.5%]	AL1050[99.5%]	AL1050[99.5%]	AL1050[99.5%]
Finish	anodize black	Clear	Clear	Clear
Weight [kg]	0.863 kg	0.088kg	0.116kg	0.003kg
thermal resistance	0.67 K/W	5.7 K/W	4.95 K/W	8.64 K/W

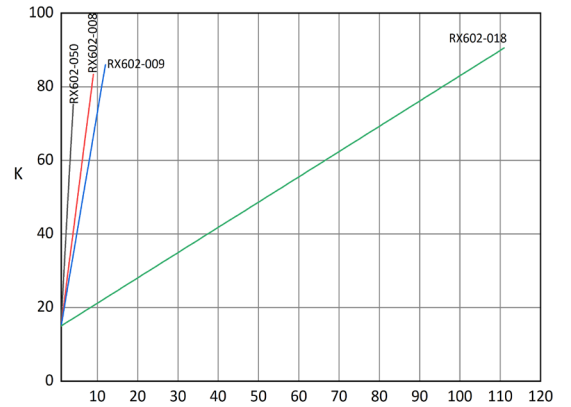

Square W 125 ~ W 125 mm Splayed Pin Fin heat sink

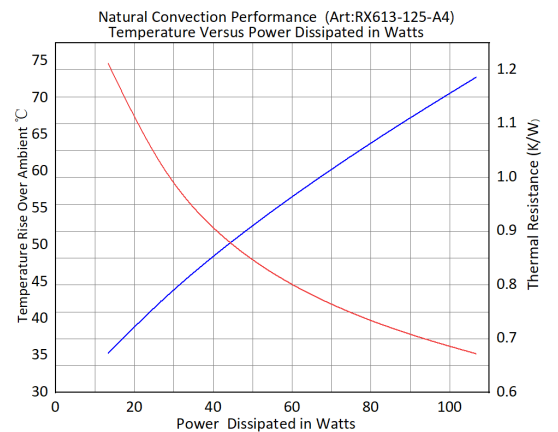
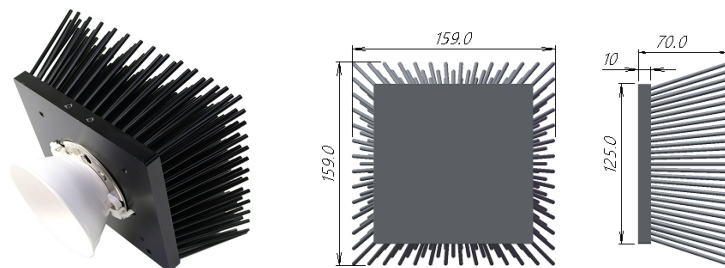

Square L 306 ~ W 255 mm Forging Fin heat sink
art no: RX602-062-A1 material :AL1050 [99.5%] Weight: 3.58 kg

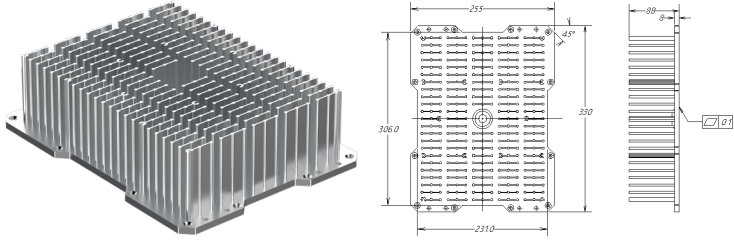

Square L 75.5 ~ W 50.6 mm Forging Fin heat sink
art no: RX612-002-A4 material :AL1050 [99.5%] Weight: 73.55 g

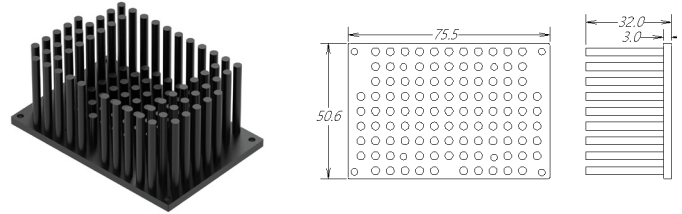

round OD 210 x H 58 mm Forging Fin heat sink
art no: RX602-060-A1 material :AL1050 [99.5%] Weight: 1.361 kg

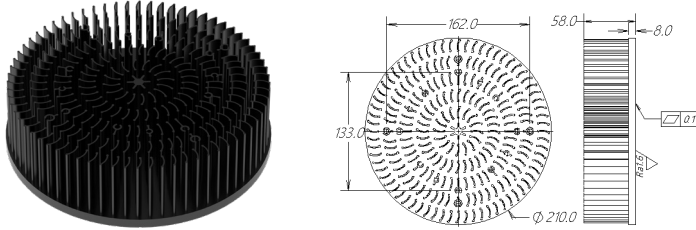

round OD 50 x H 17.8 mm Forging Fin heat sink
art no: RX602-049-A1 material :AL1050 [99.5%] Weight: 27.47 g

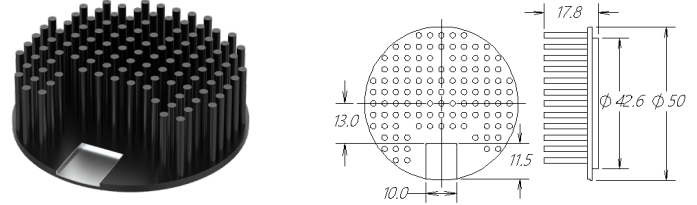

Round OD 50 x H 17.8 mm Forging Fin heat sink
art no: RX602-040-A3 material :AL1050 [99.5%] Weight: 27.47 g

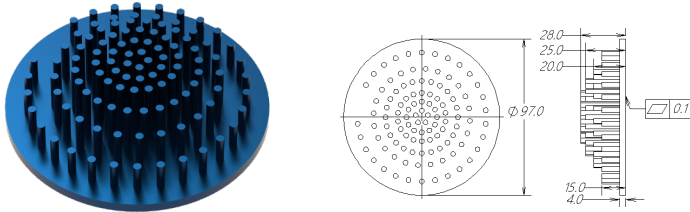

Square L 128 ~ W 90 mm Forging Fin heat sink
art no: RX620-801-A1 material :AL1050 [99.5%] Weight: 440.7 g

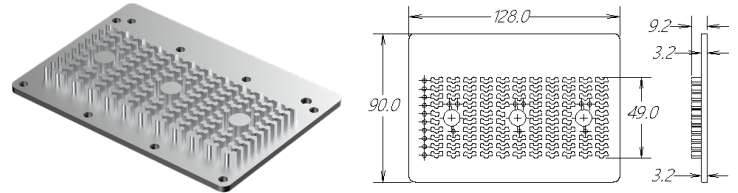

Square L 87 ~ W 70 mm Forging Fin heat sink
art no: RX602-037-A4 material :AL1050 [99.5%] Weight: 426.7 g

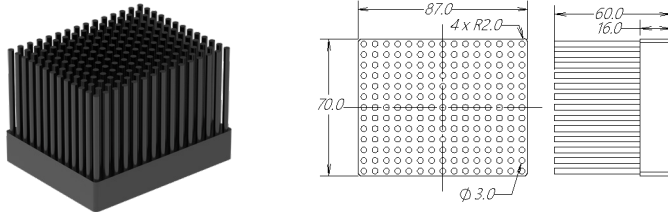

Splayed Pin L 19 x 19 mm Forging pin heat sink
art no: RX602-052-A4 material :AL1050 [99.5%] Weight: 5 g

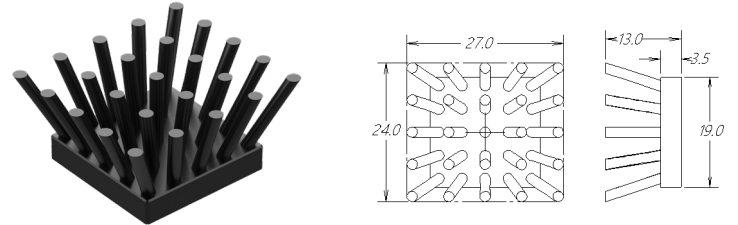

Square L 104 ~ W 83 mm Forging Fin heat sink
art no: RX602-027-A4 material :AL1050 [99.5%] Weight: 224.97 g

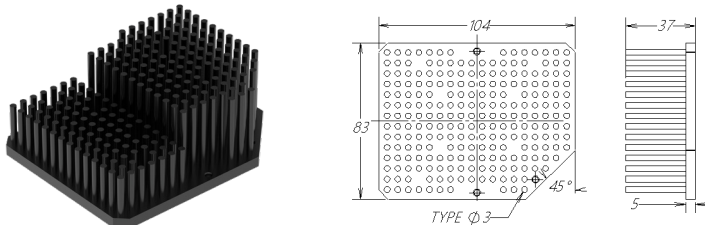

Square L 152 ~ W 92 mm Forging Fin heat sink
art no: RX620-802-A1 material :AL1050 [99.5%] Weight: 148.1 g

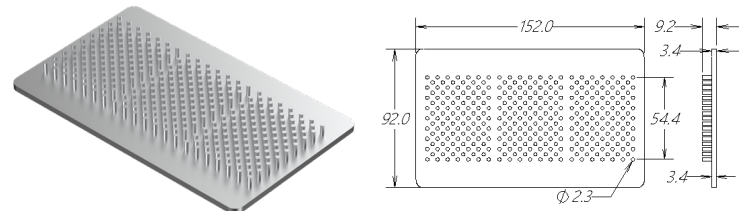

Round OD 108 x H 38 mm Forging Fin heat sink
art no: RX602-024-A1 material :AL1050 [99.5%] Weight: 385 kg

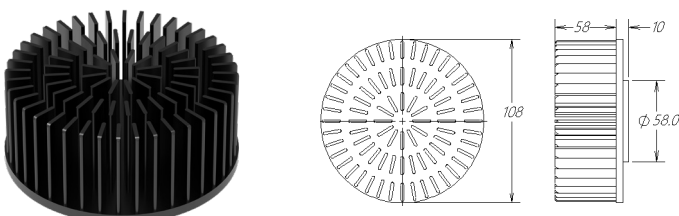

Square L 264.8 ~ W 72.2 mm Forging Fin heat sink
art no: RX620-086-A1 material :C1100 [T2] Weight: 724.1 g

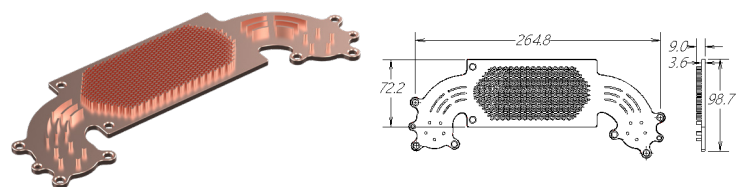

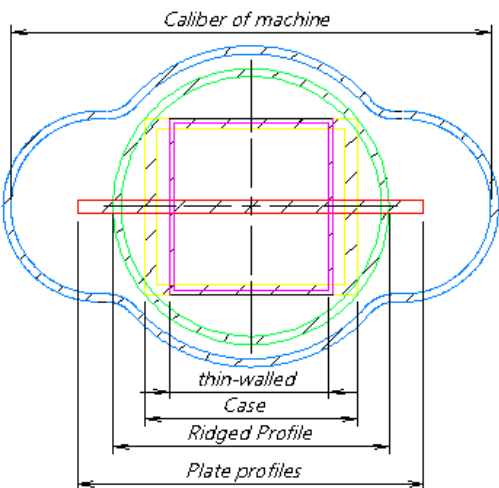
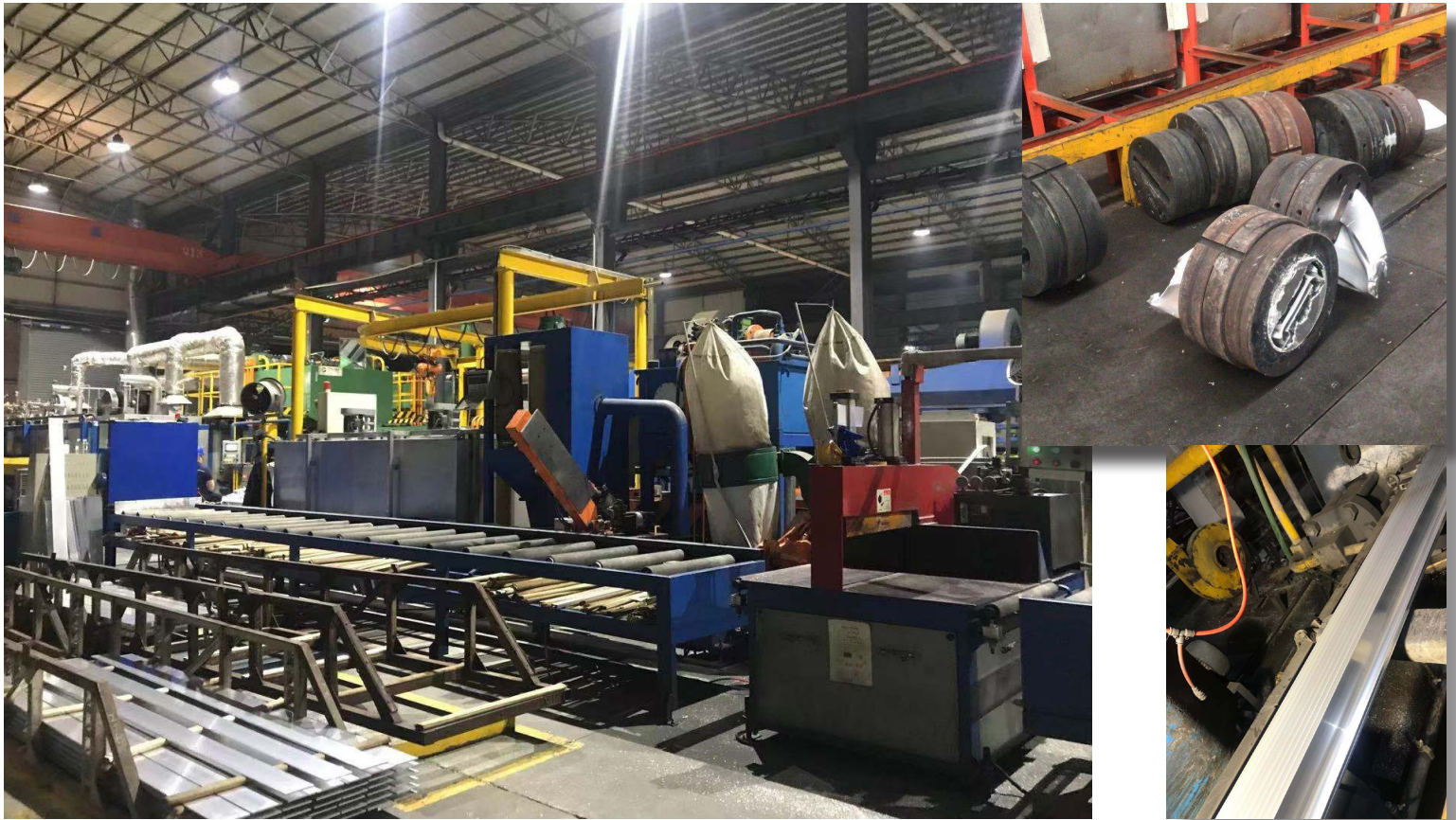
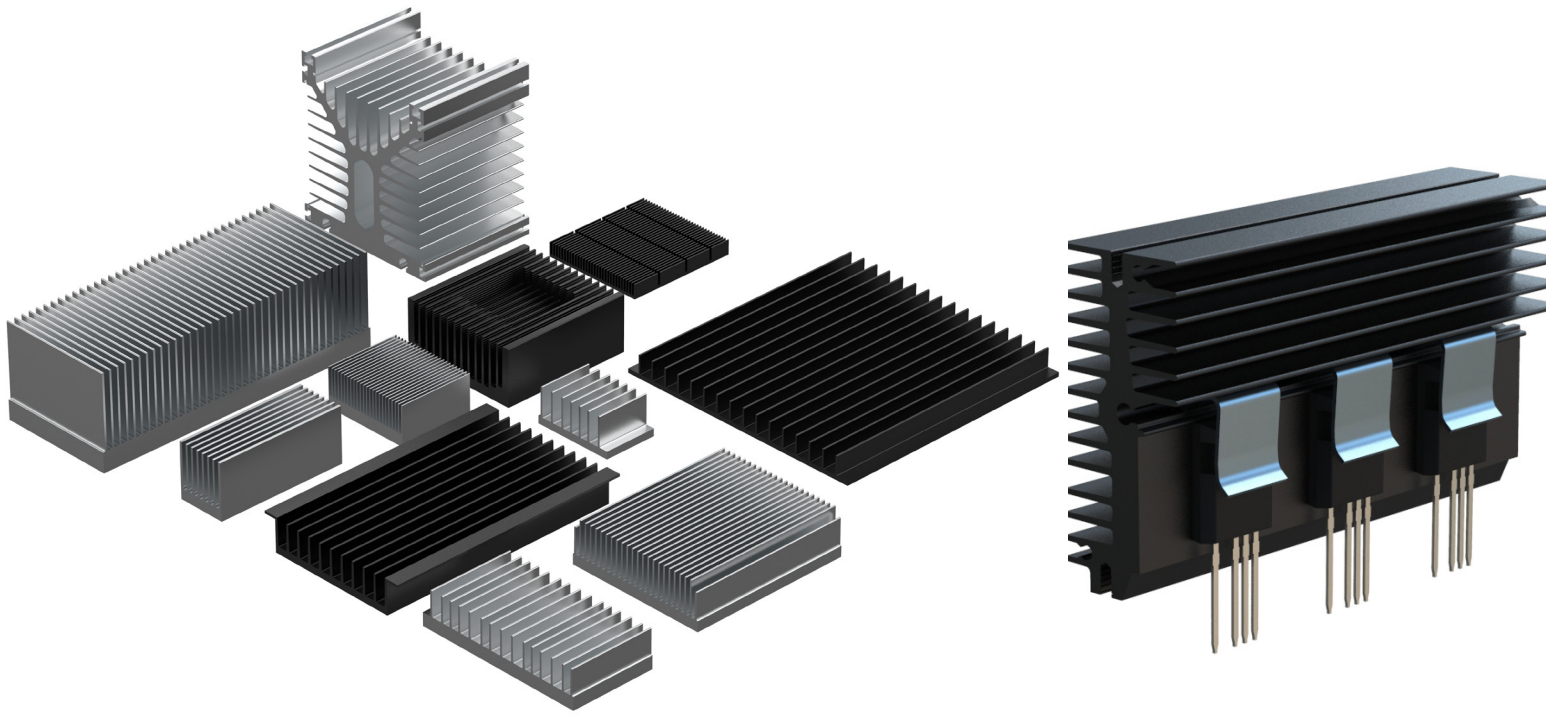

Aluminum Profiles Extruded Capacity Chart Renxin.Thermal

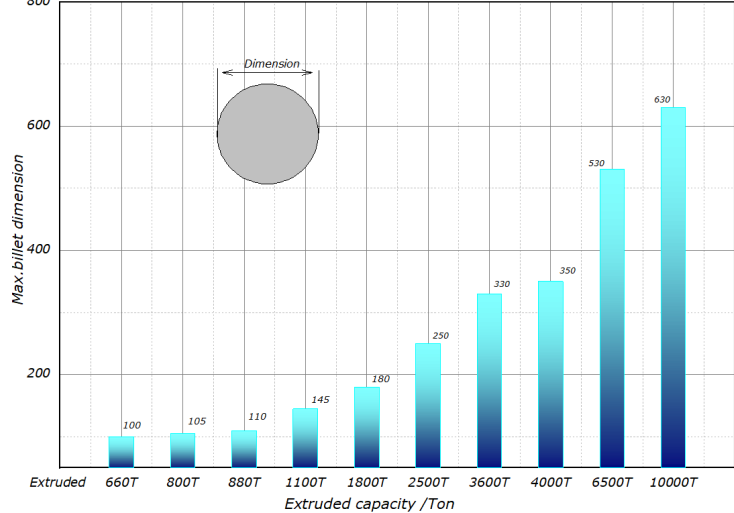

Extruded Profiles Heatsink [挤压型材系列]

Features & Benefits

- Used for industrial purpose such as heat sink, solar panel frame and machine parts
- Different extruded profiles can be supplied according to customer's requirements
- Up to 10,000 ton capacity extrusion machine , max dimension 630 [24.8"]
- Provide various customized finishing and Silk-print

Extruded profiles Width [10 ~ 100 mm]

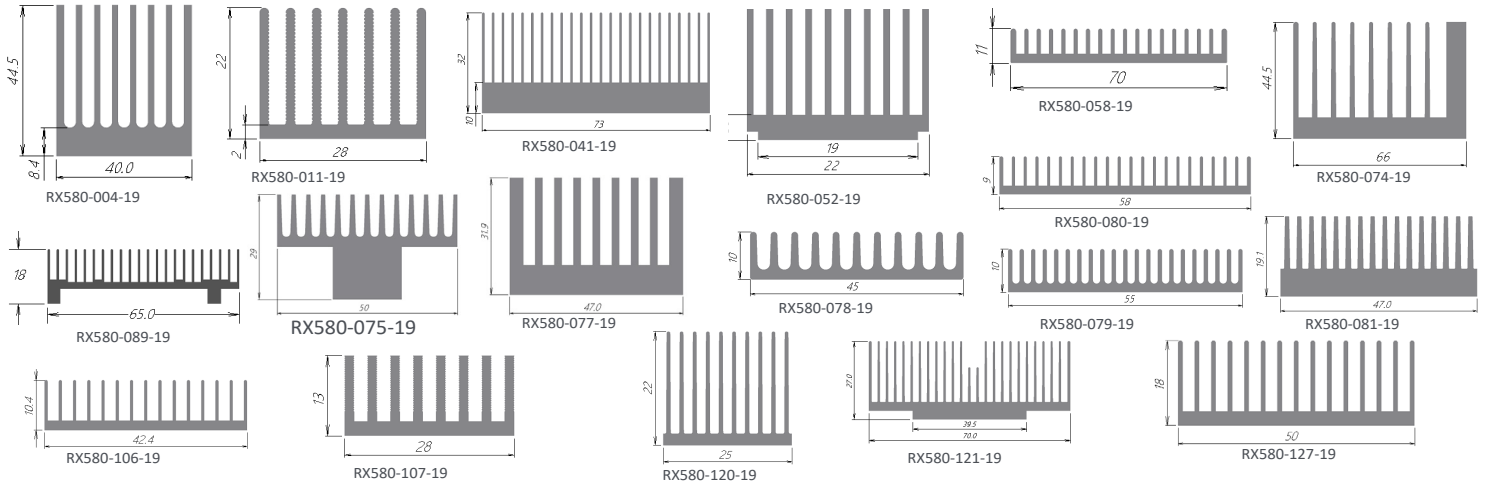

Extruded profiles Width [100 ~ 200 mm]

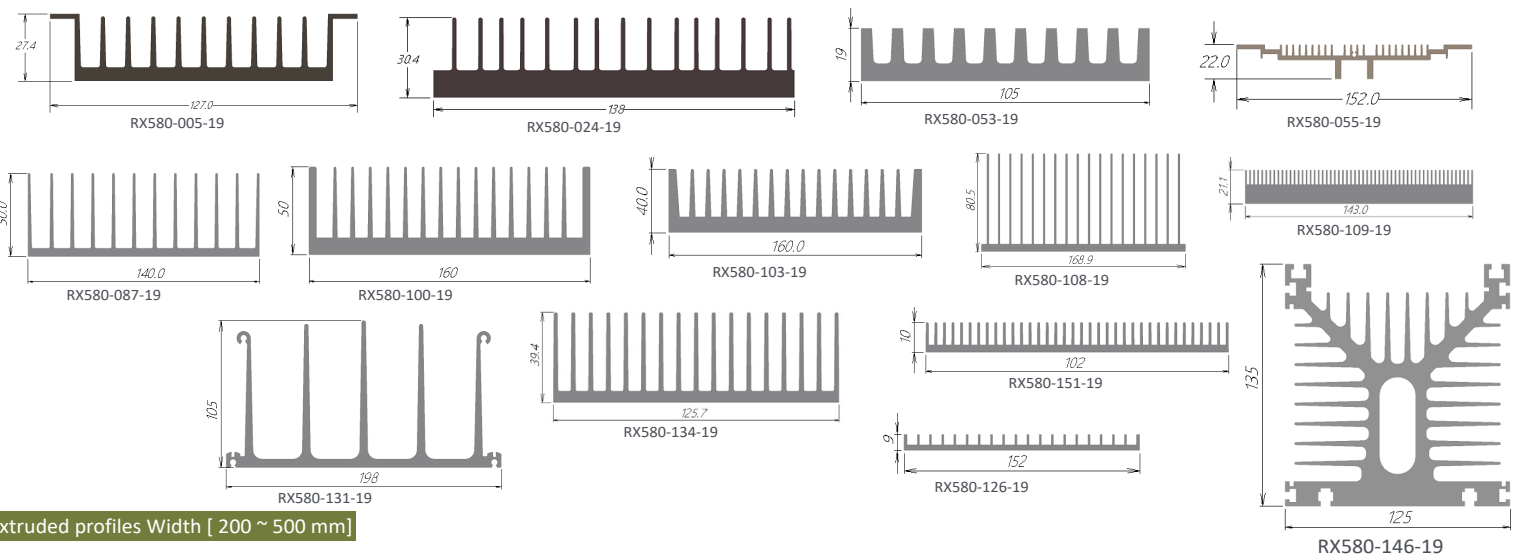

Extruded profiles Width [200 ~ 500 mm]

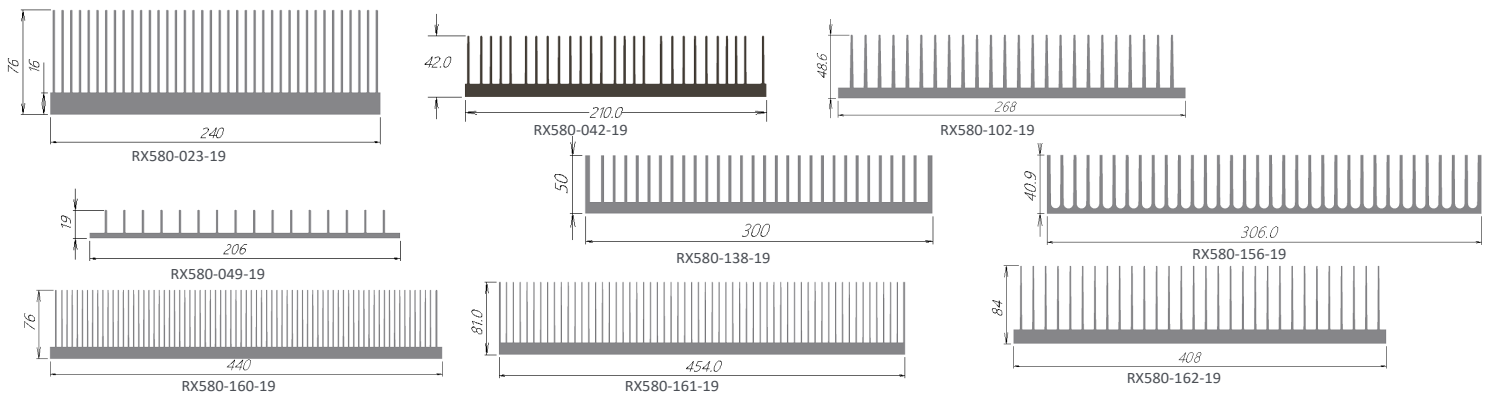

art no RX580-004-19 - Weight: 2.45 kg/meter

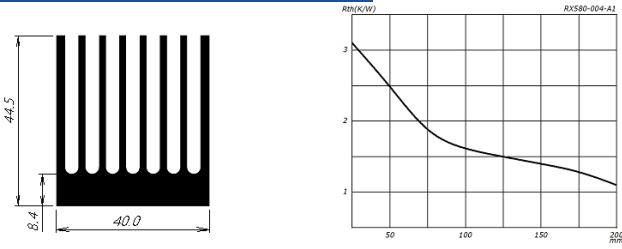

art no RX580-011-19 - Weight: 0.75 kg/meter

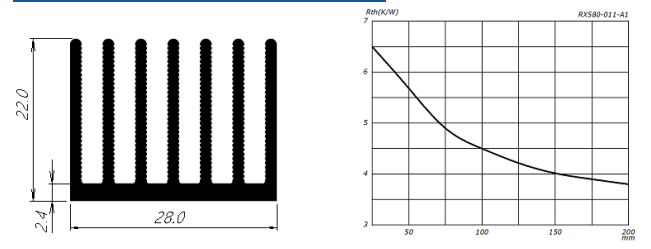

art no RX580-023-19 - Weight: 20.91 kg/meter

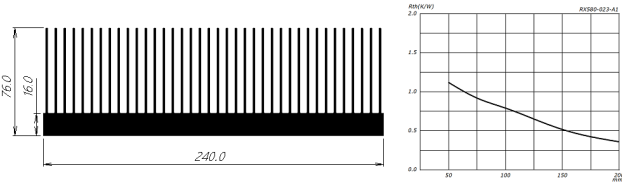

art no RX580-024-19 - Weight: 5.32 kg/meter

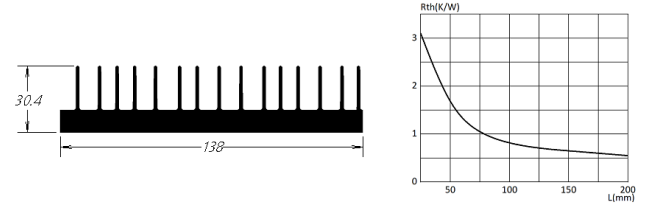

art no RX580-041-19 - Weight: 3.12 kg/meter

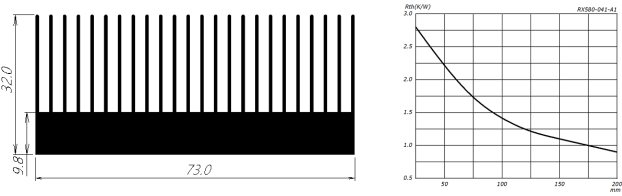

art no RX580-042-19 - Weight: 6.94 kg/meter

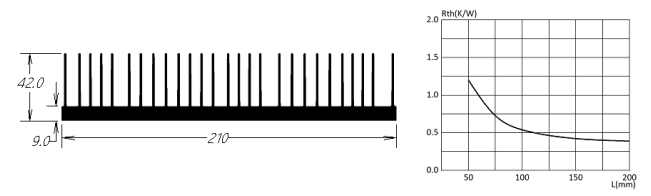

art no RX580-049-19 - Weight: 2.93 kg/meter

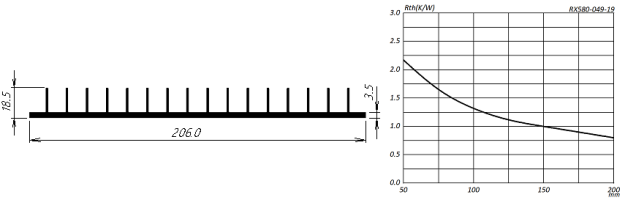

art no RX580-052-19 - Weight: 0.45 kg/meter

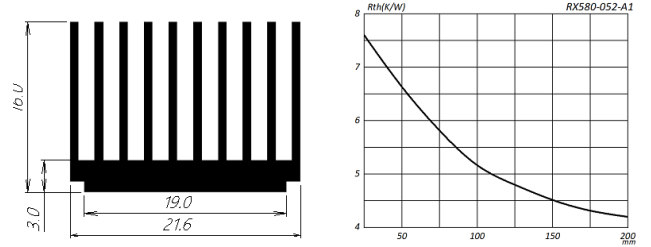

art no RX580-053-19 - Weight: 3.36 kg/meter

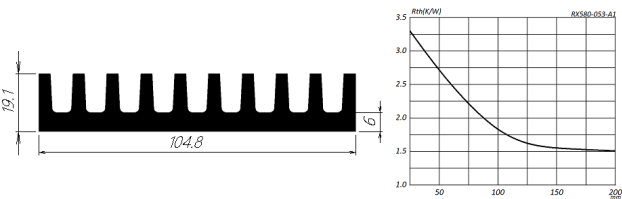

art no RX580-058-19 - Weight: 1.09 kg/meter

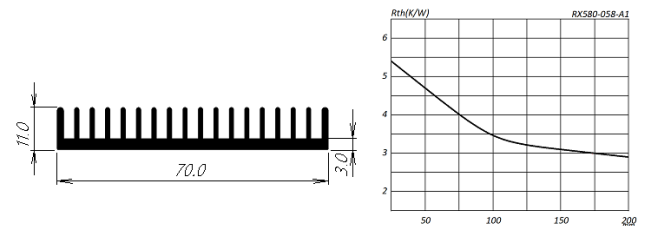

art no RX580-074-19 - Weight: 3.62 kg/meter

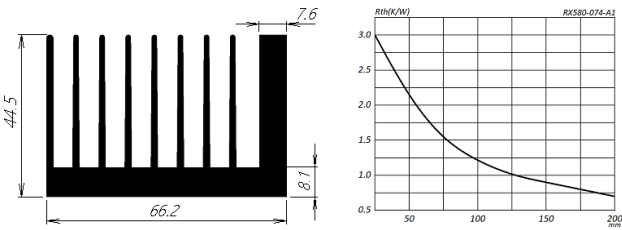

art no RX580-075-19 - Weight: 1.75 kg/meter

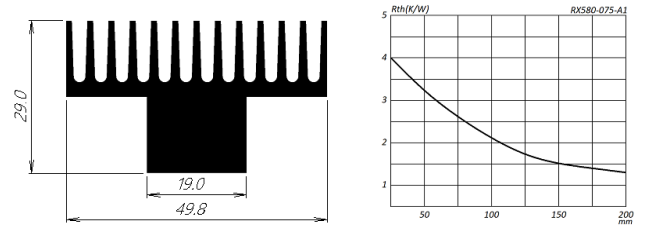

art no RX580-077-19 - Weight: 2.46 kg/meter

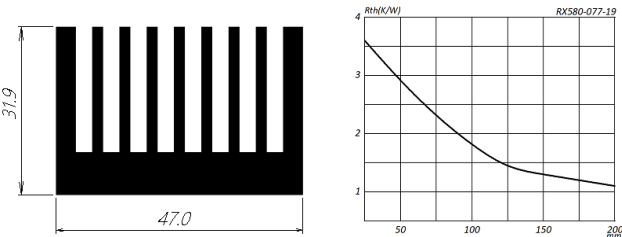

art no RX580-078-19 - Weight: 0.64 kg/meter

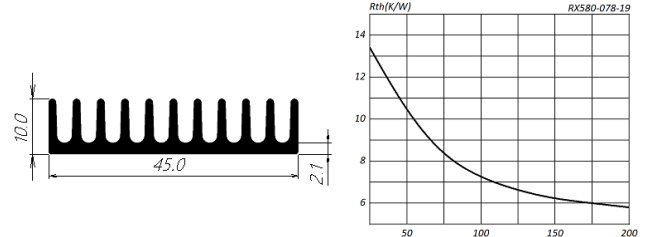

art no RX580-079-19 - Weight: 0.76 kg/meter

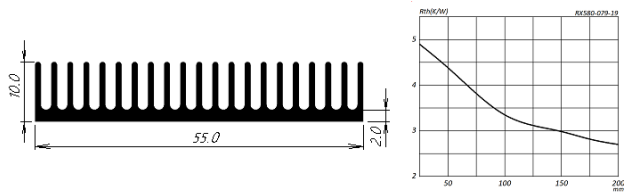

art no RX580-080-19 - Weight: 0.6 kg/meter

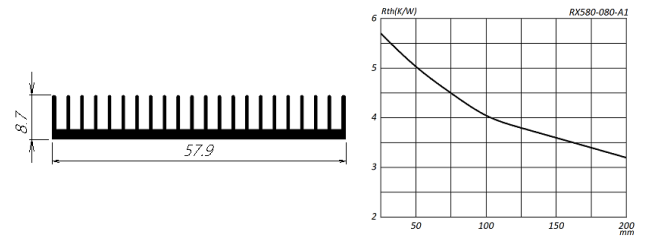

art no RX580-081-19 - Weight: 1.5 kg/meter

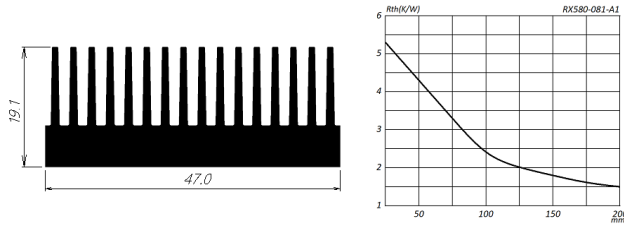

art no RX580-087-19 - Weight: 4.8 kg/meter

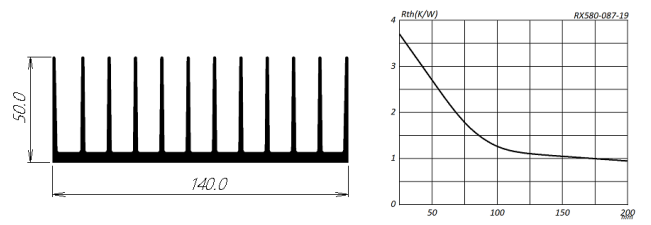

art no RX580-100-19 - Weight: 8.6 kg/meter

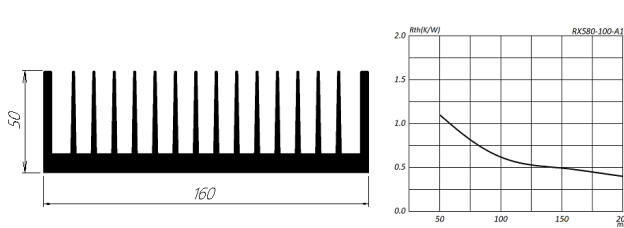

art no RX580-103-19 - Weight: 8.67 kg/meter

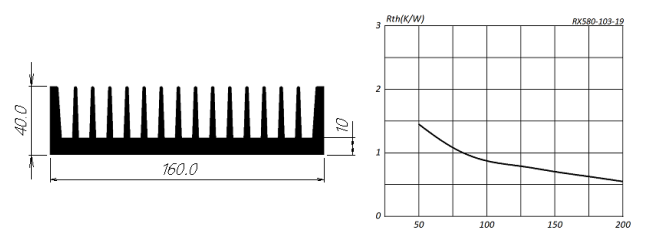

art no RX580-102-19 - Weight: 11.85 kg/meter

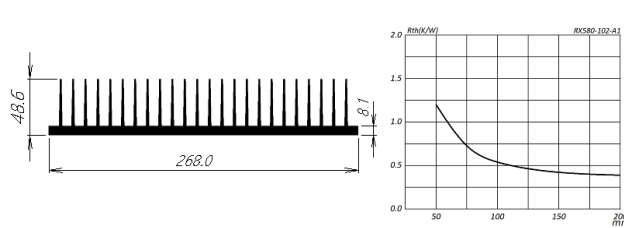

art no RX580-106-19 - Weight: 0.46 kg/meter

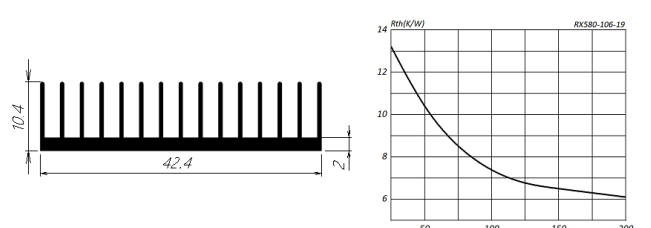

art no RX580-108-19 - Weight: 9.33 kg/meter

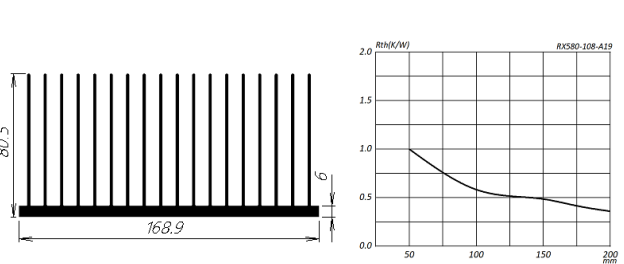

art no RX580-109-19 - Weight: 6.04 kg/meter

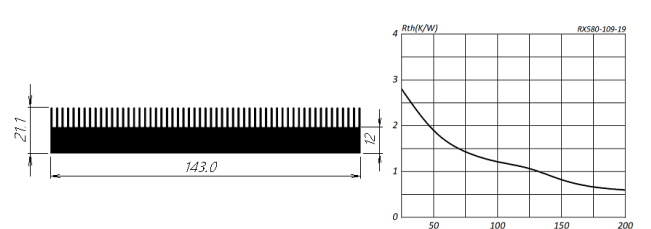

art no RX581-146-19 - Weight: 16.44 kg/meter

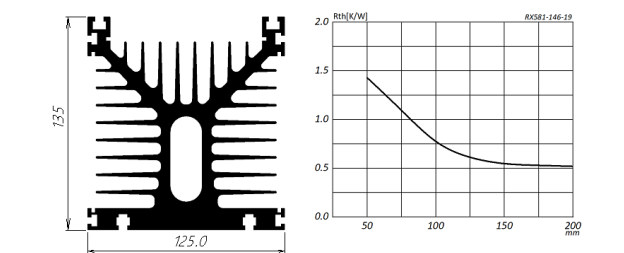

art no RX580-160-19 - Weight: 33.51 kg/meter

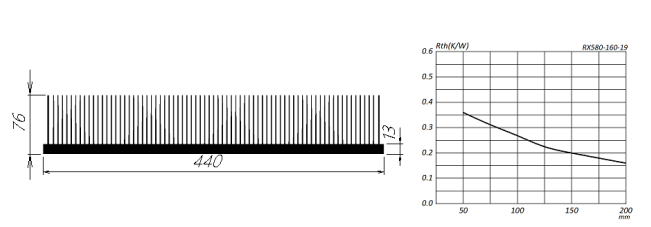

art no RX580-161-19 - Weight: 31.85 kg/meter

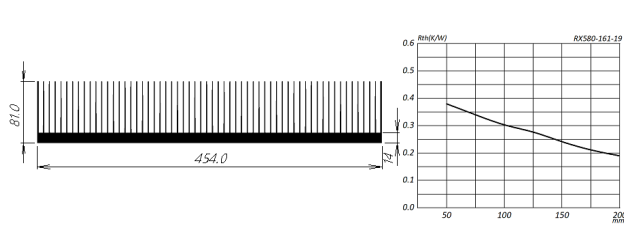

art no RX580-162-19 - Weight: 28.12 kg/meter

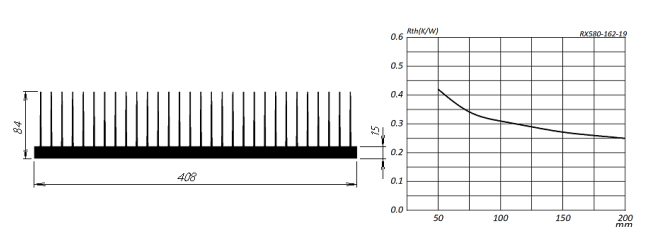

art no RX580-056-A4 - Weight: 1.13 kg/meter

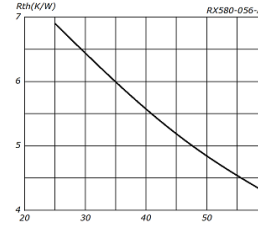
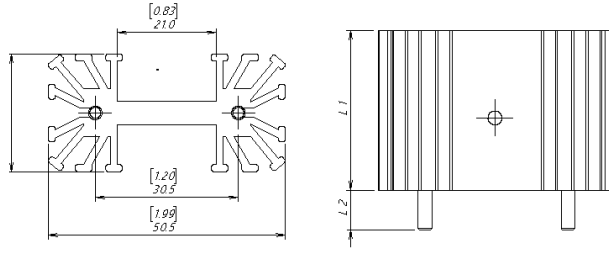
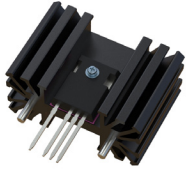

art no RX580-086-A4 - Weight: 0.73 kg/meter

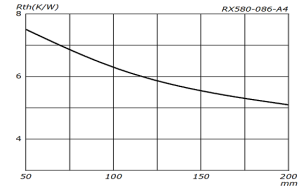
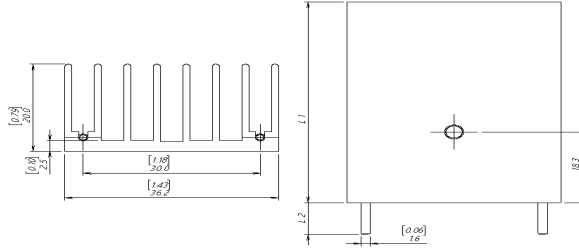
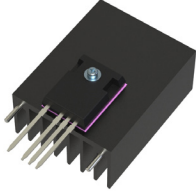

art no RX580-101-A4 - Weight: 0.92 kg/meter

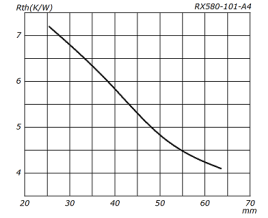
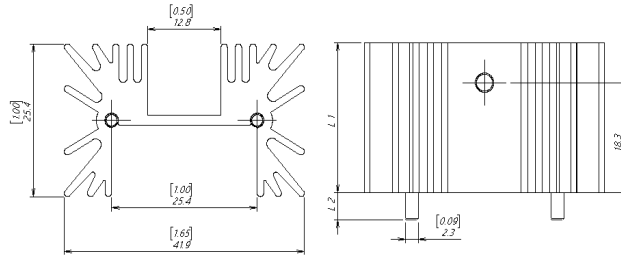
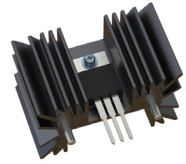

art no RX580-014-A4 - Weight: 0.58 kg/meter

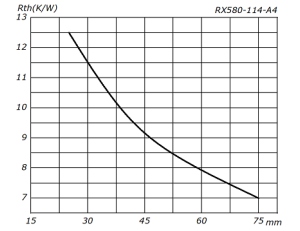
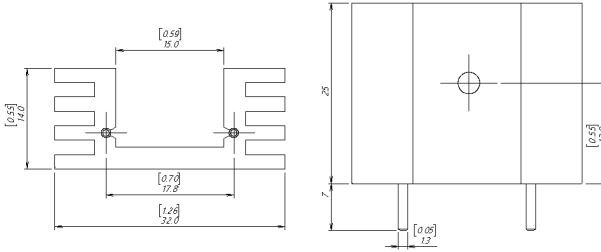
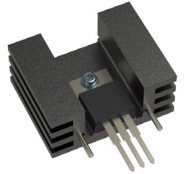

art no RX580-139-A4 - Weight: 0.94 kg/meter

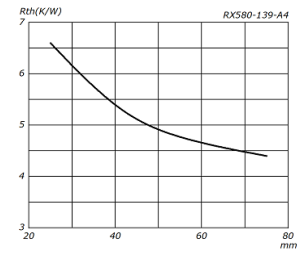
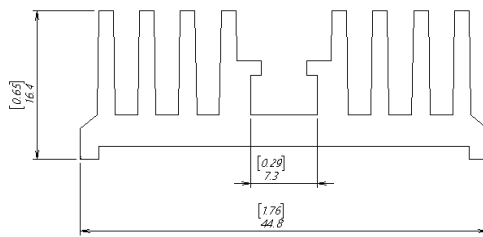
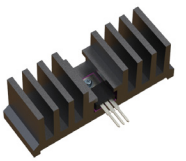

art no RX580-161-A8 - Weight: 0.49 kg/meter

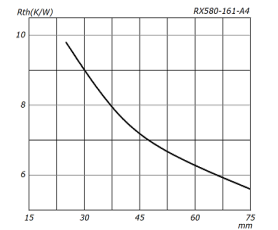
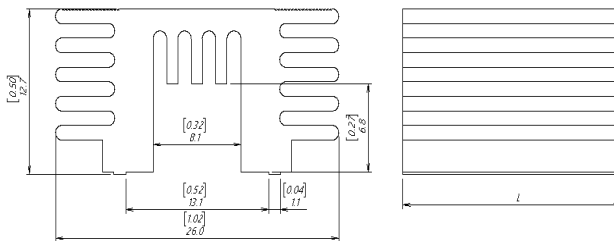
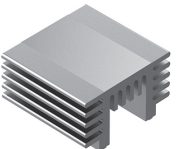

art no RX580-186-A4 - Weight: 1.65 kg/meter

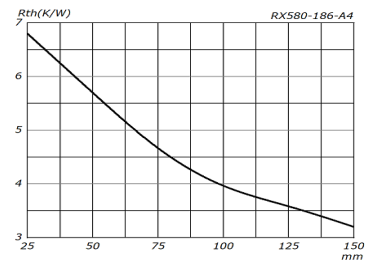
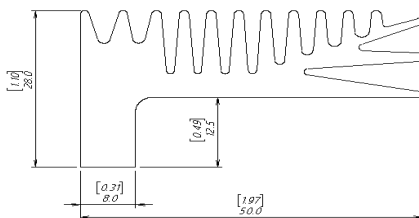
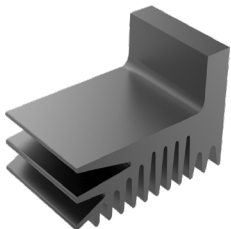

PCB Level with solder pin Heatsink [板级散热器]

art no RX580-003-A4 - Weight: 0.38 kg/meter

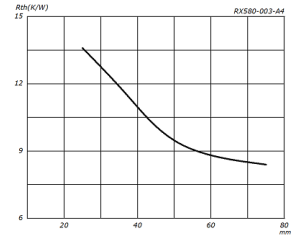
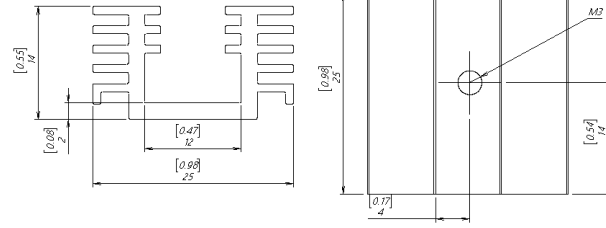
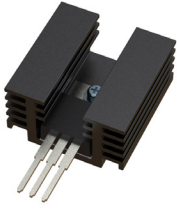

art no RX580-008-A4 - Weight: 0.59 kg/meter

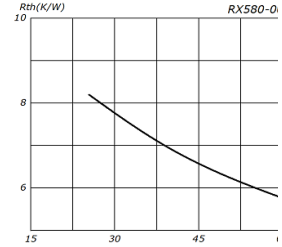
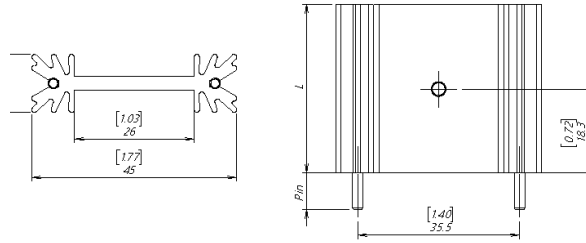
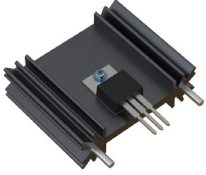

art no RX580-010-A4 - Weight: 1.22 kg/meter

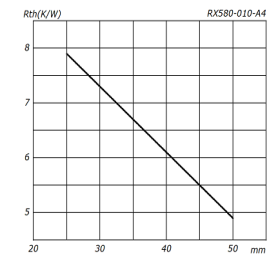
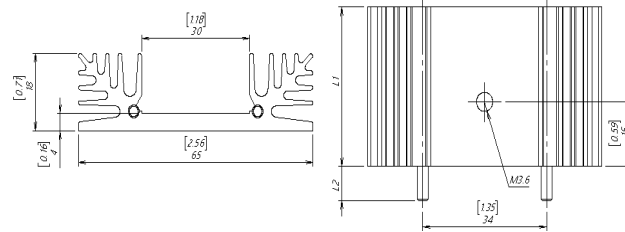
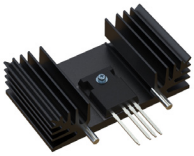

art no RX580-012-A4 - Weight: 0.38 kg/meter

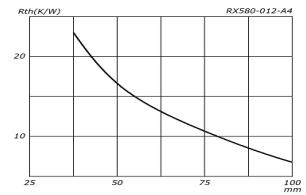
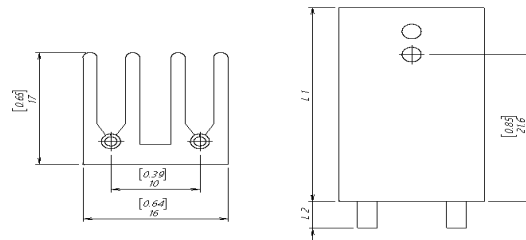

art no RX580-016-A4 - Weight: 0.31 kg/meter

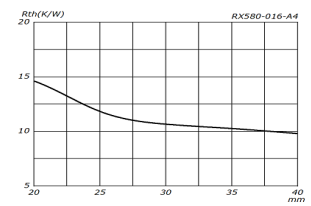
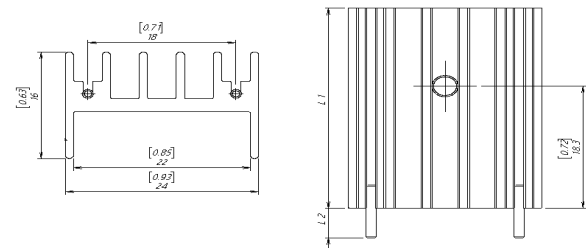
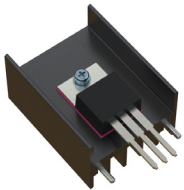

art no RX580-031-A4 - Weight: 0.96 kg/meter

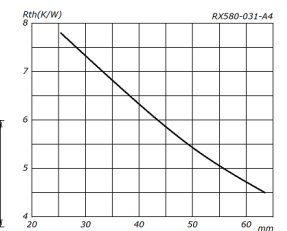
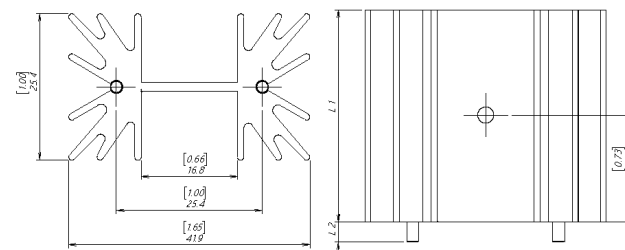
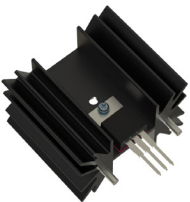

art no RX580-033-A4 - Weight: 0.78 kg/meter

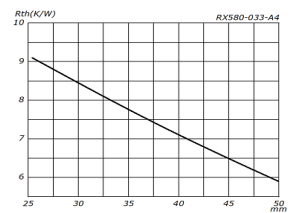
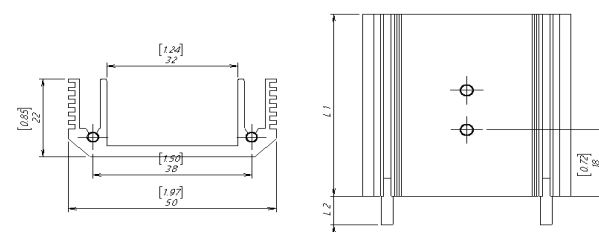
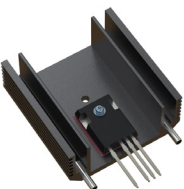

PCB Level with solder pin Heatsink

art no RX580-190-A4 - Weight: 0.352 kg/meter

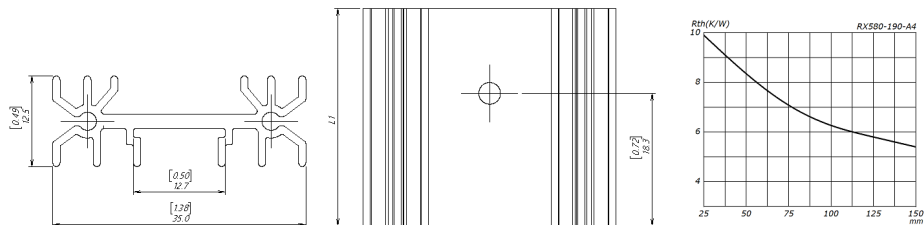
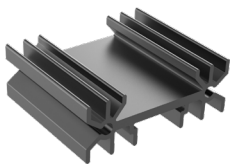

art no RX580-201-A4 - Weight: 0.53 kg/meter

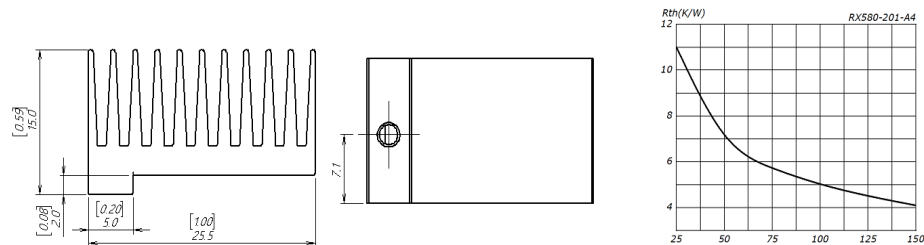
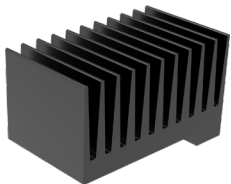

art no RX580-209-A4 - Weight: 0.31 kg/meter

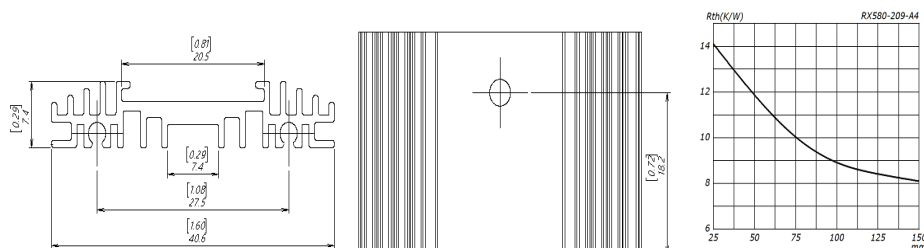
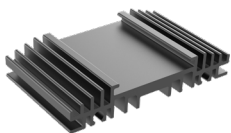

art no RX580-223-A4 - Weight: 0.51 kg/meter

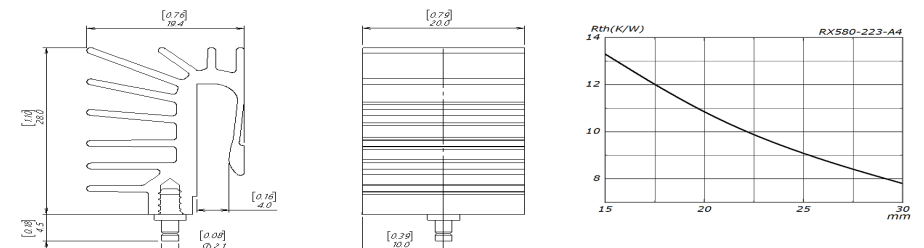
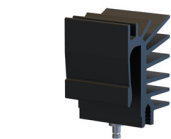

Aluminium flat-, quadrangular-, angled-, L- U- & T-profiles

- length, drilling and surface finishes to customer's instructions
- other standard profiles on request

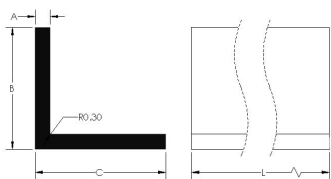

Angled profile for AL6063-T5
Tolerances: EN755

art no	A[mm]	B[mm]	C[mm]
RX584-004	2	20	20
RX584-005	2	20	30
RX584-006	2.6	25	25
RX584-007	2.6	30	35
RX584-008	3	30	40
RX584-009	3	35	45
RX584-010	3	40	52
RX584-011	3.5	40	45
RX584-012	3.5	40	40
RX584-013	4	50	55
RX584-014	4.5	40	50
RX584-015	5	65	65
RX584-016	5	65	80

Flat profile for AL6063-T5
Tolerances: EN755

art no	W[mm]	T[mm]	art no	W[mm]	T[mm]
RX584-032	25	5	RX584-040	50	54
RX584-026	30	8	RX584-040	55	37
RX584-027	30	15	RX584-029	60	30
RX584-030	30	10	RX584-028	70	15
RX584-025	40	8	RX584-038	70	74
RX584-033	40	20	RX584-036	80	60
RX584-035	40	5	RX584-040	90	79
RX584-037	40	7	RX584-040	100	100
RX584-039	40	28	RX584-040	100	112
RX584-031	120	15	RX584-034	115	100

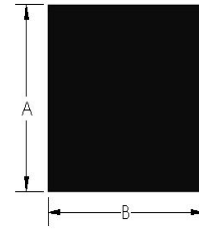
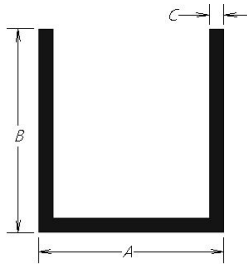

"U" profile for AL6063-T5 Tolerances:EN755

art no	A[mm]	B[mm]	C[mm]	art no	A[mm]	B[mm]	C[mm]
RX580-300	20	20	2	RX580-305	40	40	2.5
RX580-301	20	30	2	RX580-306	40	45	3
RX580-302	30	30	3	RX580-307	40	50	3
RX580-303	30	40	3	RX580-308	40	50	5

Quadrangular profile for AL6063-T5 Tolerances:EN755

art no	A [mm]	B [mm]	art no	A [mm]	B [mm]
RX580-324	8	8	RX580-330	20	20
RX580-325	10	10	RX580-331	30	30
RX580-326	12	12	RX580-332	40	40
RX580-327	15	15	RX580-333	50	50

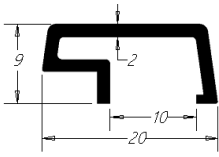

art no RX580-014-19

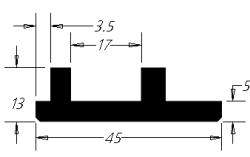

art no RX580-028-19

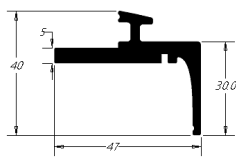

art no RX580-034-19

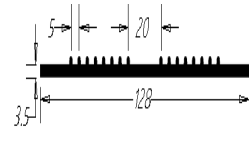

art no RX580-044-19

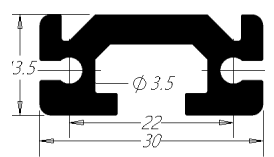

art no RX580-071-19

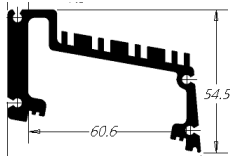

art no RX580-110-19

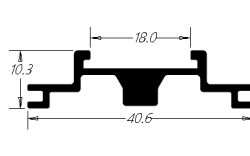

art no RX580-111-19

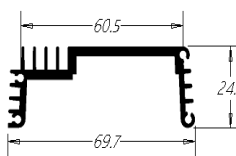

art no RX580-118-19

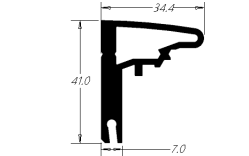

art no RX580-124-19

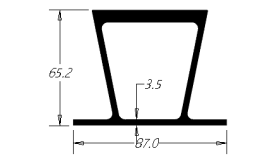

art no RX580-162-19

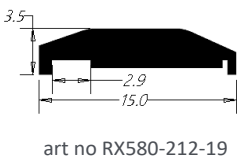

art no RX580-212-19

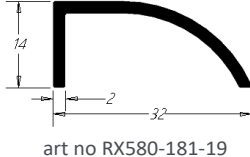

art no RX580-181-19

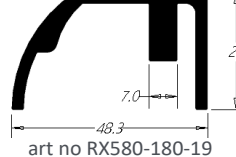

art no RX580-180-19

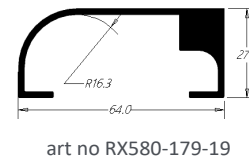

art no RX580-179-19

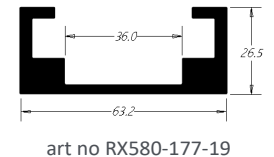

art no RX580-177-19

Aluminum Extruded heatsinks for lock-in retaining spring

art no RX580-002-A4 Weight: 3.74 kg/meter

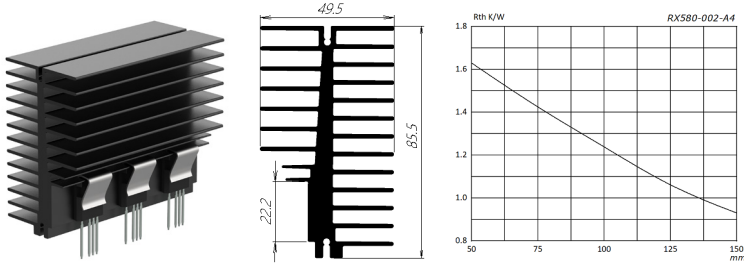

art no RX580-119-A4 Weight: 2.89 kg/meter

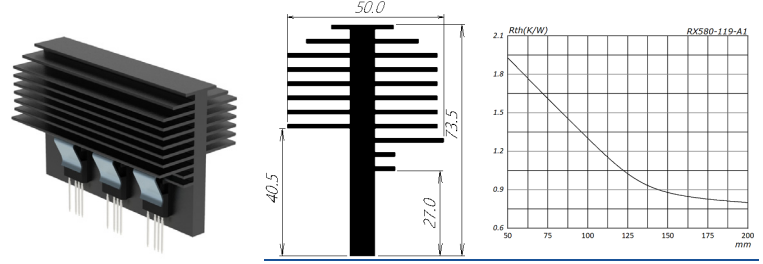

art no RX580-227-A4 Weight: 4.0 kg/meter

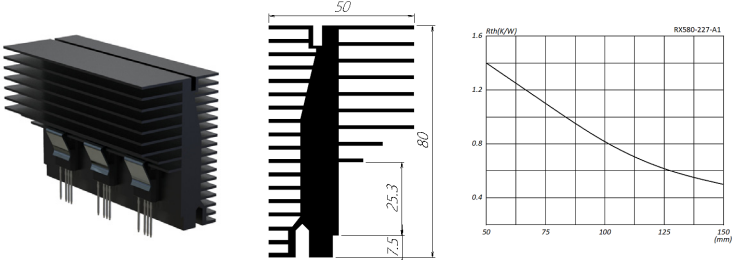

art no RX580-228-A4 Weight: 1.67 kg/meter

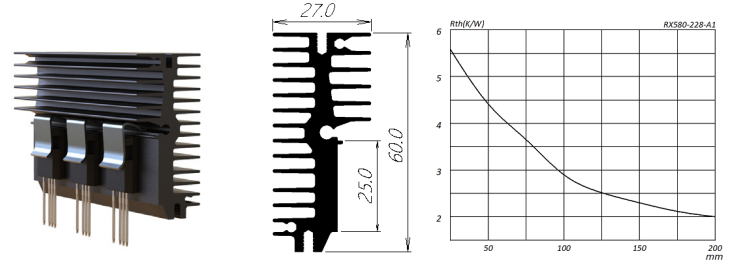

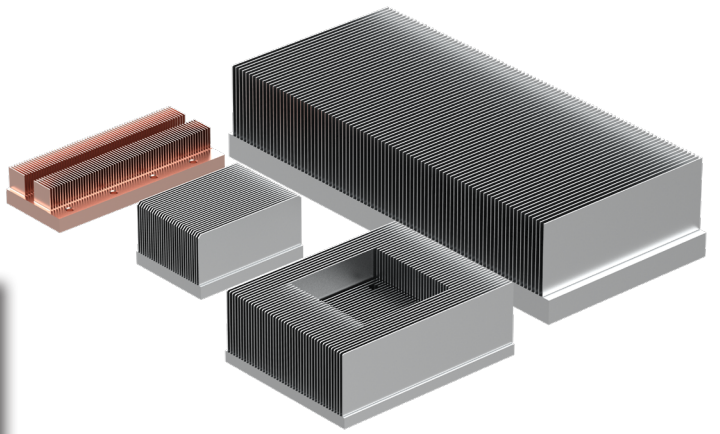
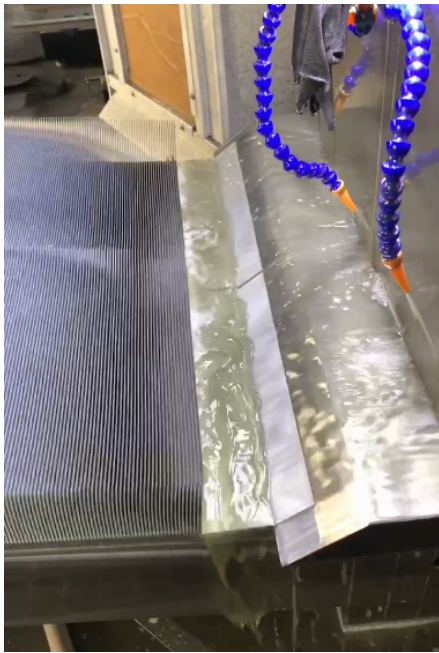

- 1、铲片散热片的 FIN 与齿间比的倍数可以达到 1:85
- 2、材质使用高导热率铝 AL6063 或铜 C1100
- 3、散热器大宽度同挤压散热器，可以节省模具费
- 4、灵活的后加工工艺可以自由定制和设计各种高密度的散热产品

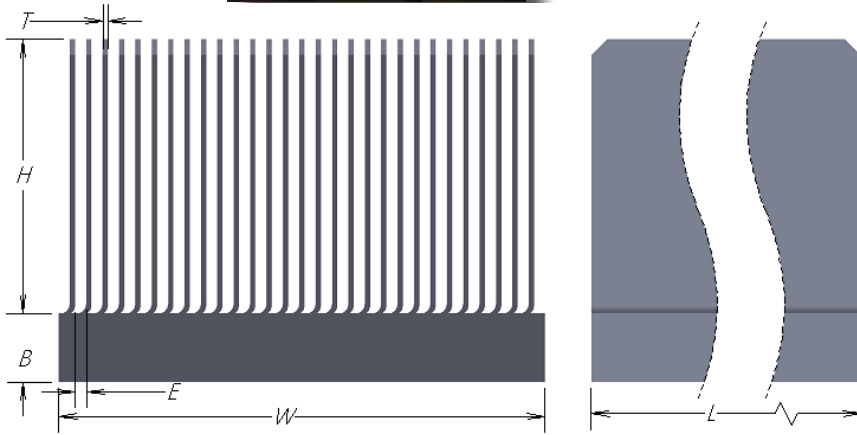

material	W [mm]	H [mm]	T [mm]	E [mm]	L [mm]
Aluminum	750	140	0.2 ~ 2	T vs E [1:1]	1,500
Copper	300	60	0.2 ~ 2	T vs E [1:1]	1,500

Skived Heatsink for Aluminum

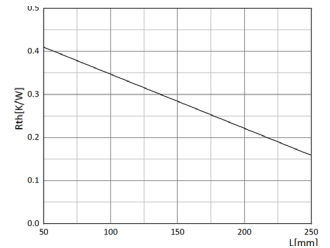
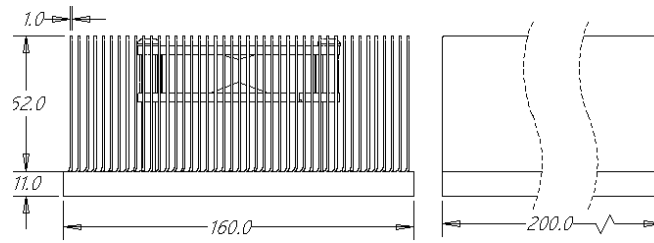
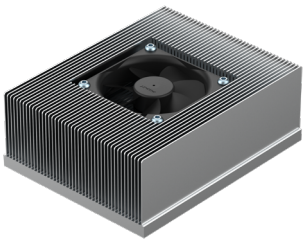

Skived Heatsink for Copper C1100

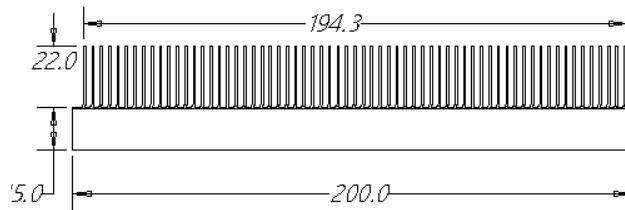
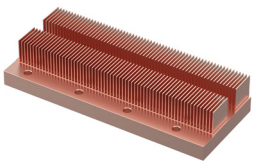

Skived Heatsink + Heat Pipe

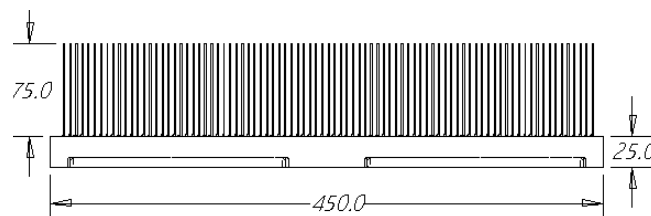
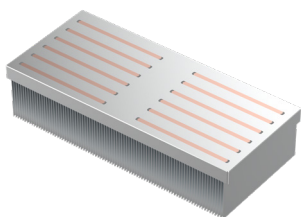

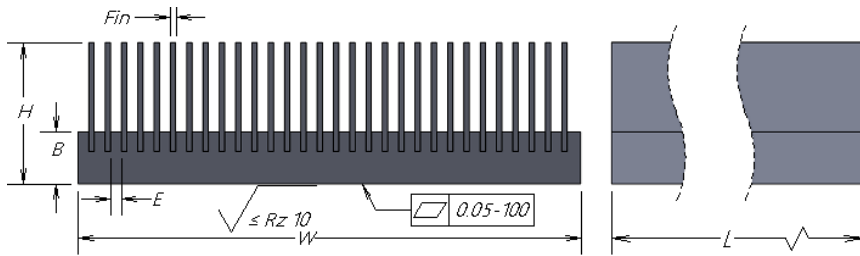
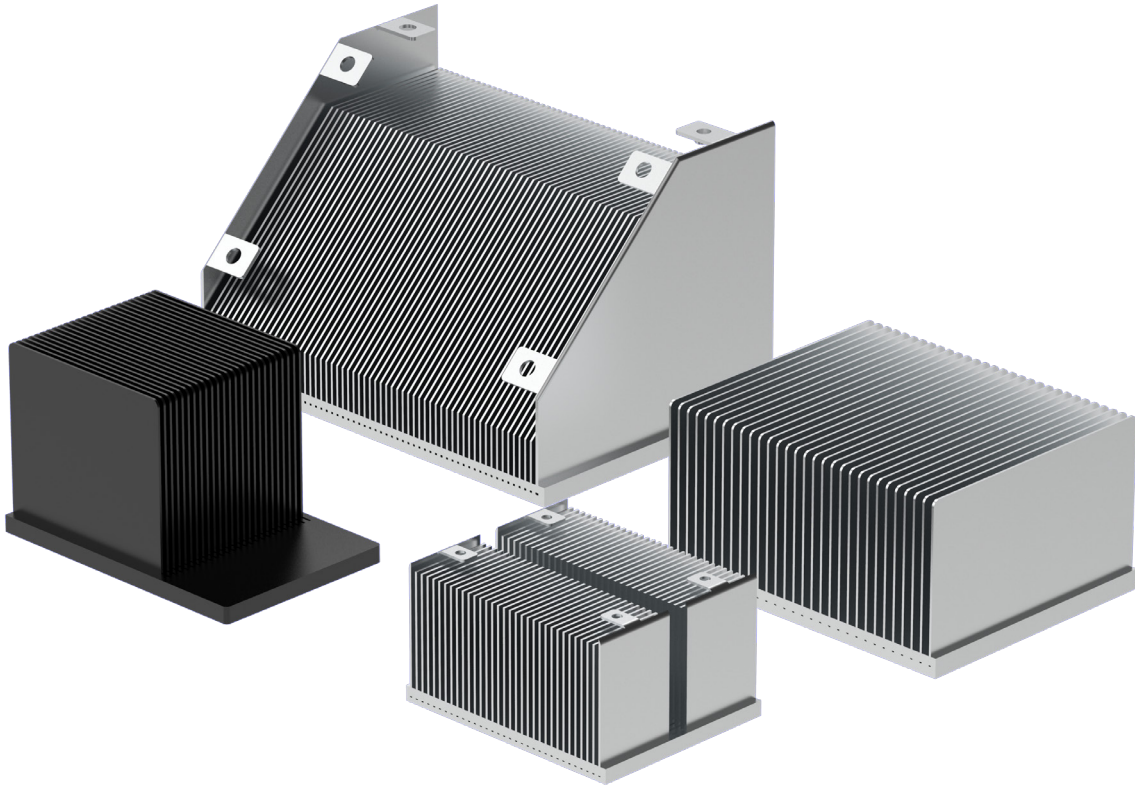

material	W [mm]	H [mm]	B [mm]	Fin [mm]	L [mm]
Aluminum	Max > 750	Max > 400	Max > 30	0.8/1.0/1.2/1.6/2.0	Max >2400

[特点]

- 1: 采用定制化的散热鳍片紧凑设计，体积减小，鳍片的高度与间距能突破传统挤压型材的倍齿工艺限制。
- 2: 插片散热器的尺寸不受传统挤压模具的尺寸限制，可以更大表面积，比挤压型材更高效的换热面积。
- 3: 强迫风冷工况下空气冷却时热阻特别低，特别适用于热电元件 (Peltier 元件) 和类似功率模块。
- 4: 支持特定的特殊设计、底部经过精密平铣加工，表面粗糙度非常低 $Ra < 1.6$ 。
- 5: 可以安装相变热管等特殊结构，从热工程师的角度是理想的选择

Stacked Fin Heatsink art no: RX618-021-A1

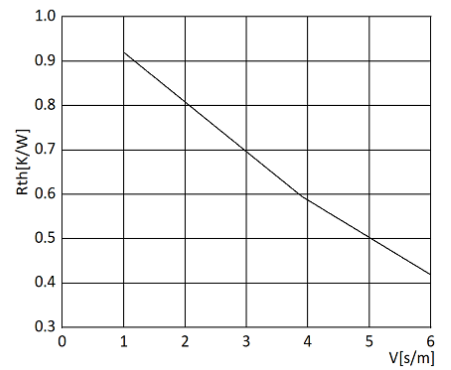
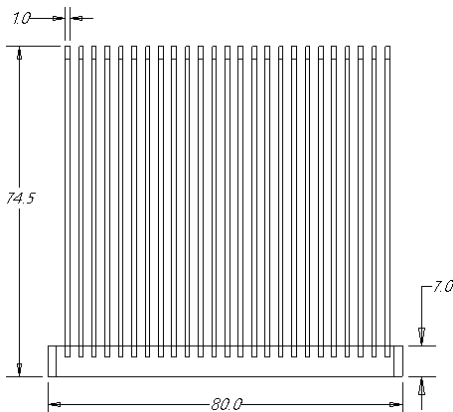
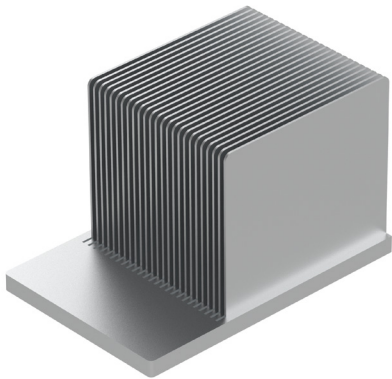

Stacked Fin Heatsink art no: RX618-121-A1

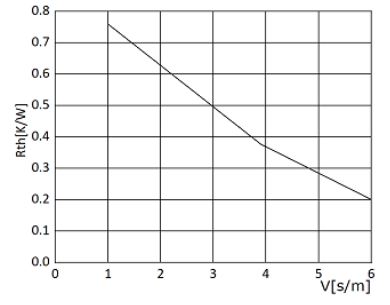
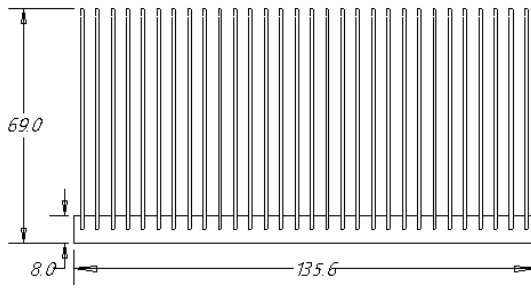
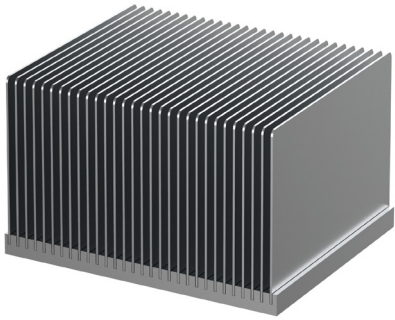

Stacked Fin Heatsink art no: RX618-087-A1

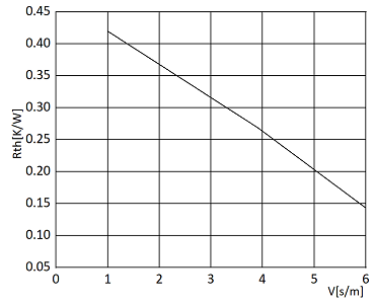
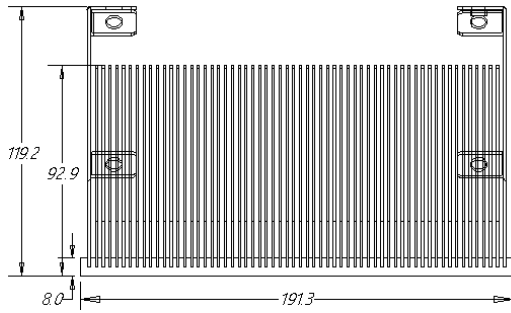
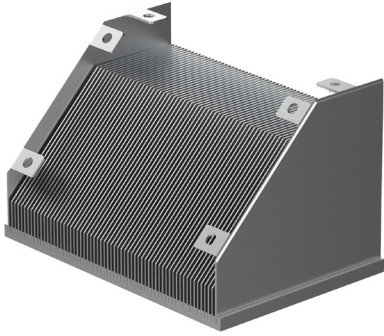

Stacked Fin Heatsink art no: RX618-066-A1

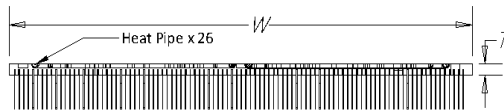
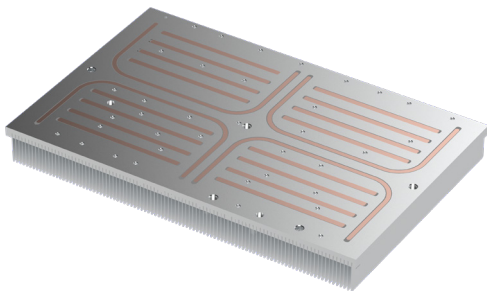



Features & Benefits

- Compact construction for dissipating high power losses on smallest installation space
- Exclusive for forced convection, fan types and fan voltages upon request
- Heatsink geometries and fixed length optimal adjusted to the fan being used, homogeneous heat dissipation
- Segment profile also sold by the meter, precise milled flat semiconductor mounting surfaces
- Additional treatments, modifications and designs according to customers specifications

Cooling aggregates art no: RX580-062-A1
Weight: 2.06 kg/meter

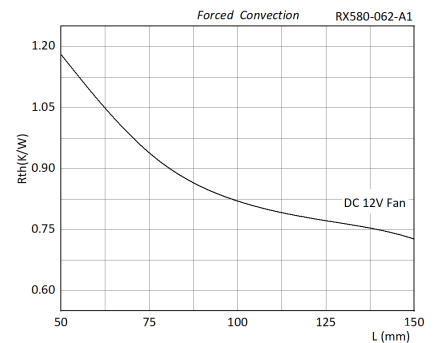
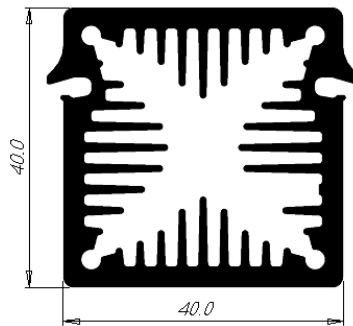
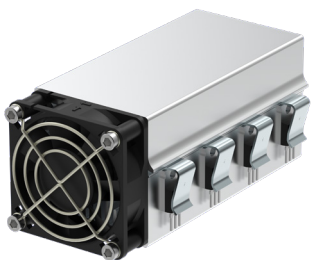

Cooling aggregates art no: RX580-063-A1
Weight: 3.57 kg/meter

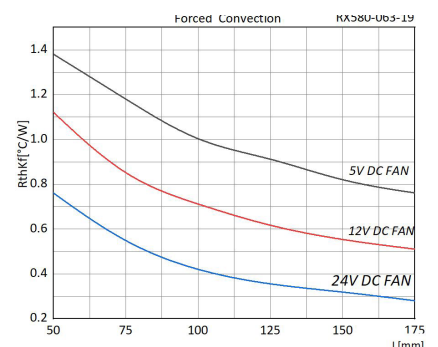
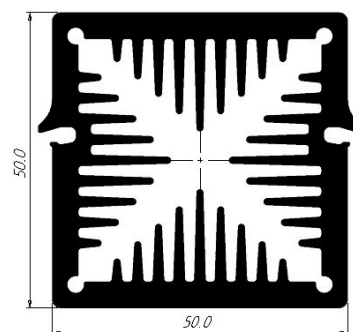
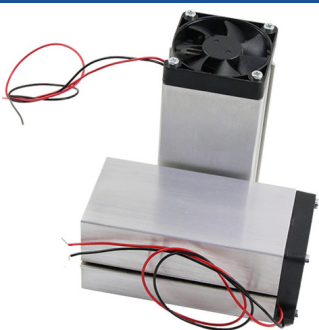

Cooling Aggregates [散热组合模块]

Cooling aggregates art no: RX580-050-A1
Weight:9.4 kg/meter

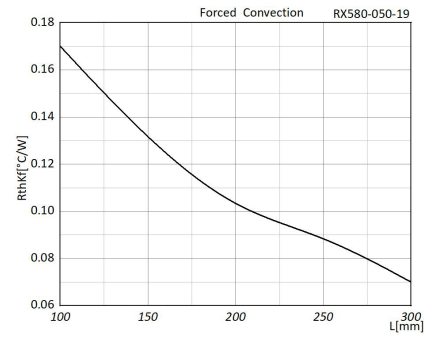
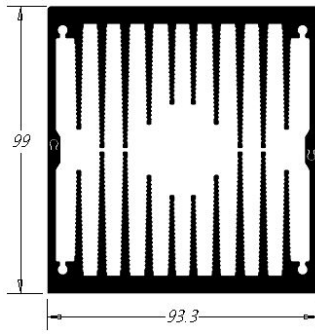

Cooling aggregates art no: RX580-120-A1
Weight:16.47 kg/meter

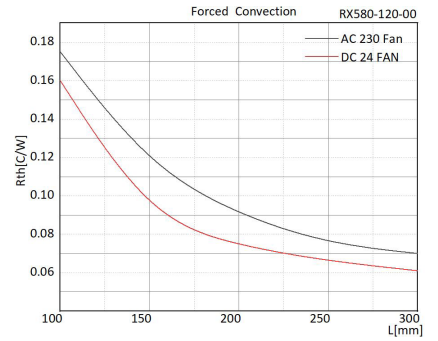
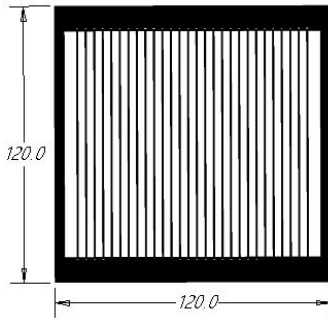

Cooling aggregates art no: RX580-100-A1
Weight:6.56 kg/meter

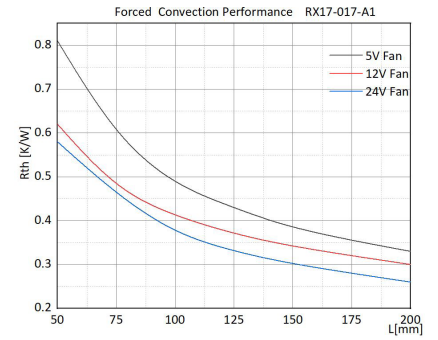
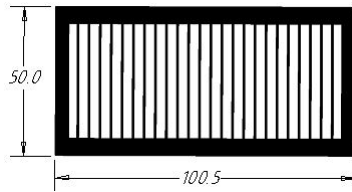

Cooling aggregates art no: RX580-062-A1
Weight:2.06 kg/meter

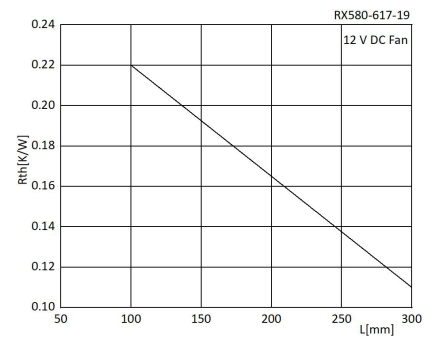
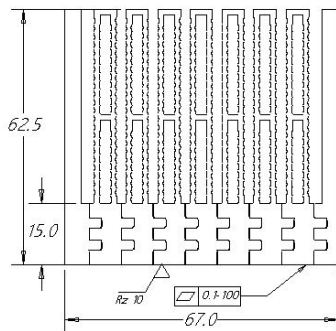

Cooling aggregates art no: RX580-062-A1
Weight:2.06 kg/meter

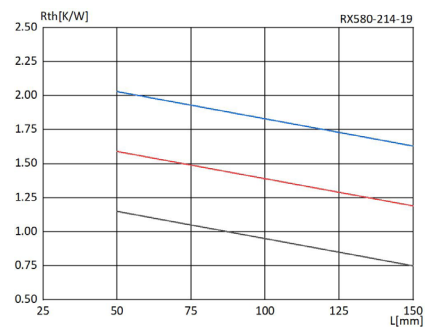
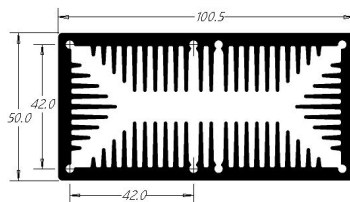
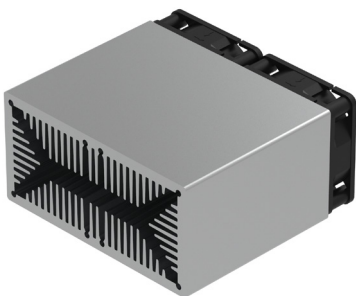

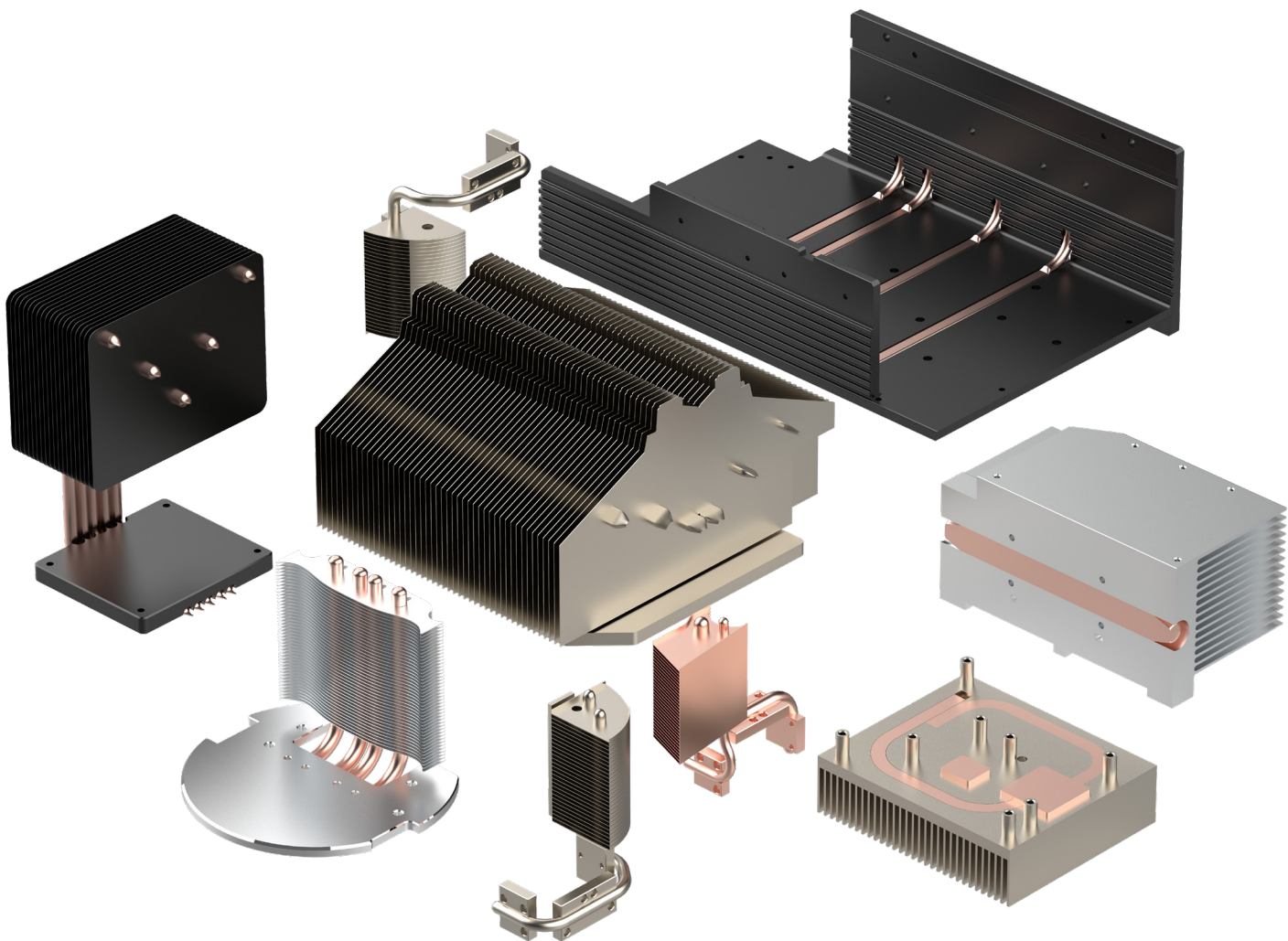

热管按运行工况可分为蒸发端，绝热段，冷凝端，其运行机理是利用工质在冷热两端蒸发 - 冷凝的相变传递过程实现热量传递，热管内部处于真空状态，使工质的蒸发 - 冷凝可以发生在低于工质常规沸点的温度下。此外热管内壁附有毛细结构（Wick structure），其作用可以加速工质蒸发冷凝的循环速度。

热管的特性：

- 1、导热性：热管内部以液体的汽 - 液相变潜热形式传热，因此热阻很小，具有很高的导热能力。与金属材料银、铝相比同单位质量，导热量多出几个数量级。
- 2、等温性：热管内蒸气处于饱和状态，工质蒸汽流动或相变时温差小，所以热管的表面温度梯度小，等温性能好
- 3、热流密度可变性的功能：热管的蒸气端输入高热流密度，在冷凝端可以输出低热流密度，即以较小的加热面积输入热量，以较大的冷却面积输出热量。
- 4、热响应性：蒸气端在启动后温度快速上升并稳定到热管的工作温度，具有快速响应的性能。
- 5、远距离传热：适合紧凑型设计的电子产品，热管蒸气端与冷凝端可以用绝热段隔开，因此可以在低温差下较远距离传递热量。
- 6、具有热二极管的热开关功能：通过外部装置可控制热管内部的液气相变过程可以制造出热管具有开关功能的控制型热管。
- 7、应用简单：热管结构简单，质量轻，体积小，无噪音，无振动。内部工质循环无须电能等能量驱动。

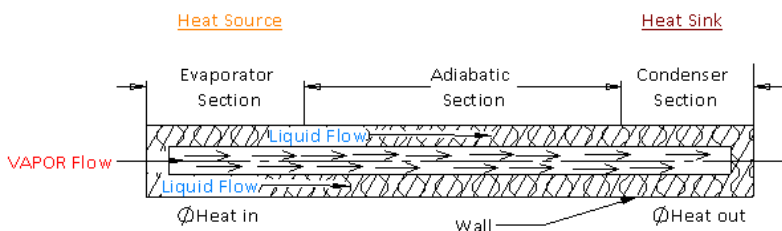

热管结构与工作原理图

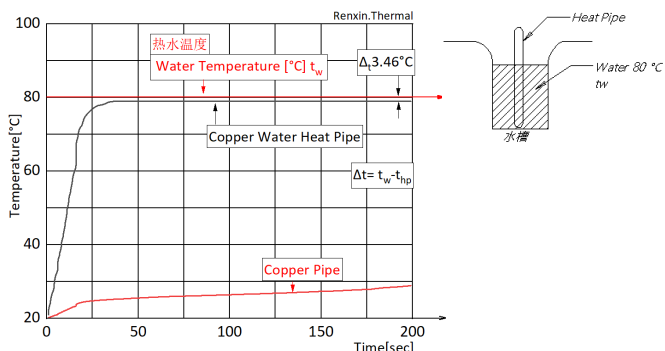

热管的热响应性图

Q-max of max of round sintered round sintered Heat Pipe

Length mm	Heat Pipe Φ [mm]			
	4	5	6	8
80~100	10W	20W	25W	30W
101~120	12W	25W	30W	40W
121~150	14W	30W	45W	60W
151~180	14W	30W	41W	60W
181~220	12W	25W	37W	50W
221~270	10W	20W	30W	45W
271~320	8W	15W	22W	35W

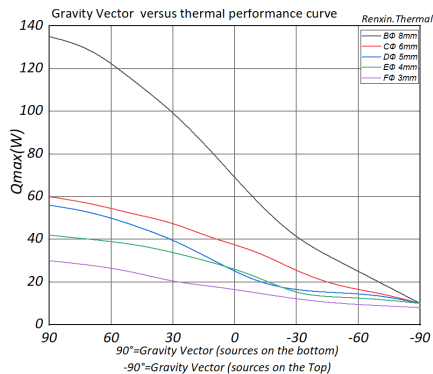

热管重力方向与热能的影响图

Heat Pipe Cooling System - [散热散热系统]

Heat Pipe Heatsink art no: RX614-016-19

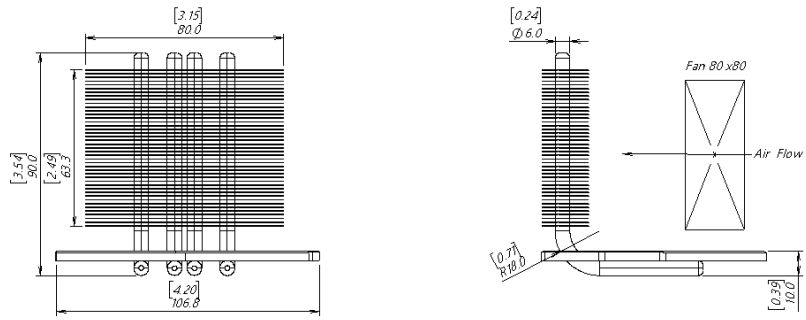
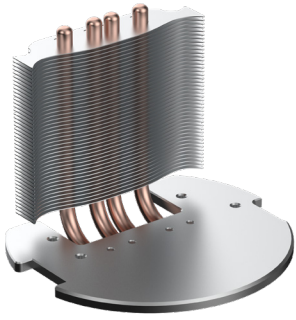

Heat Pipe Heatsink art no: RX614-211-43

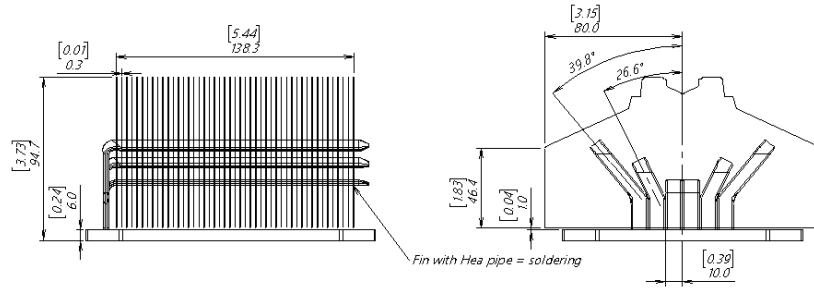
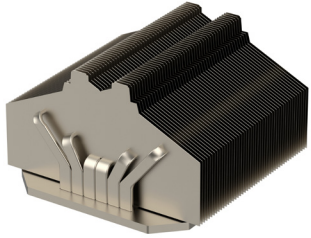

Heat Pipe Heatsink art no: RX614-051-43

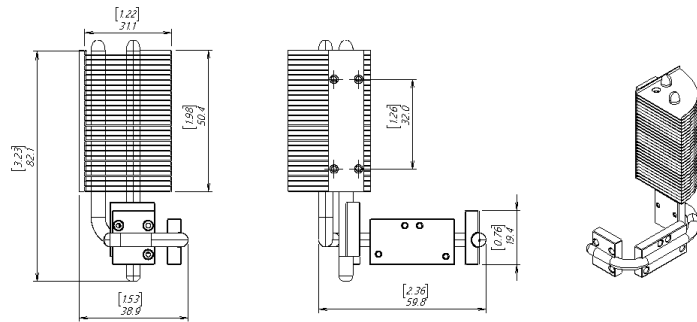
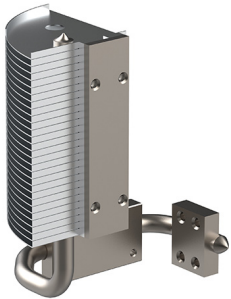

Heat Pipe Heatsink art no: RX614-324-A4

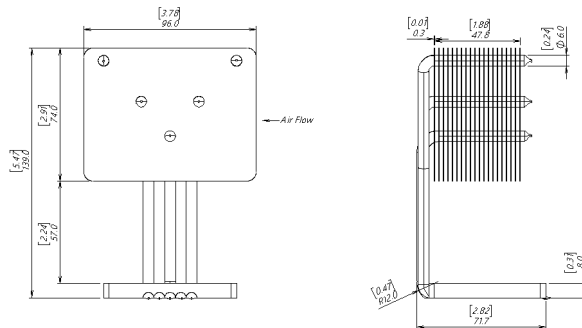
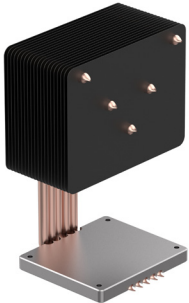

Heat Pipe Heatsink art no: RX614-144-A1

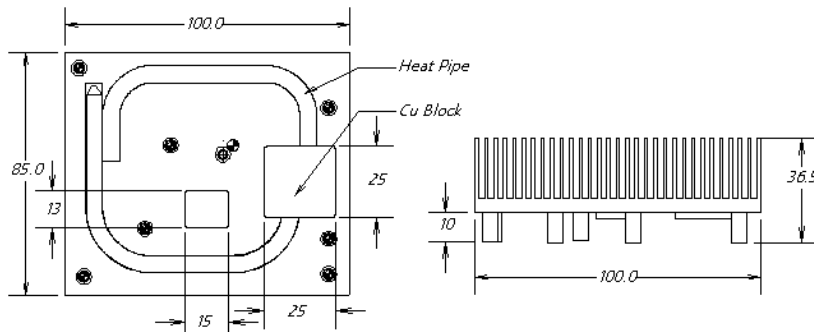
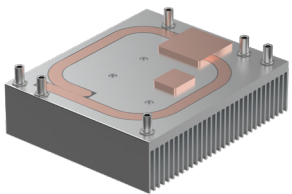

Heat Pipe Heatsink art no: RX614-071-A1

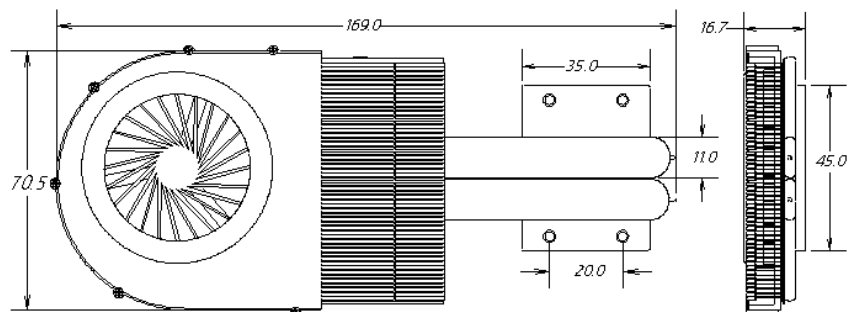
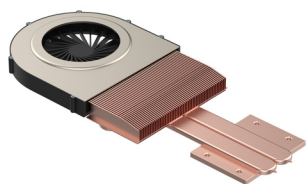

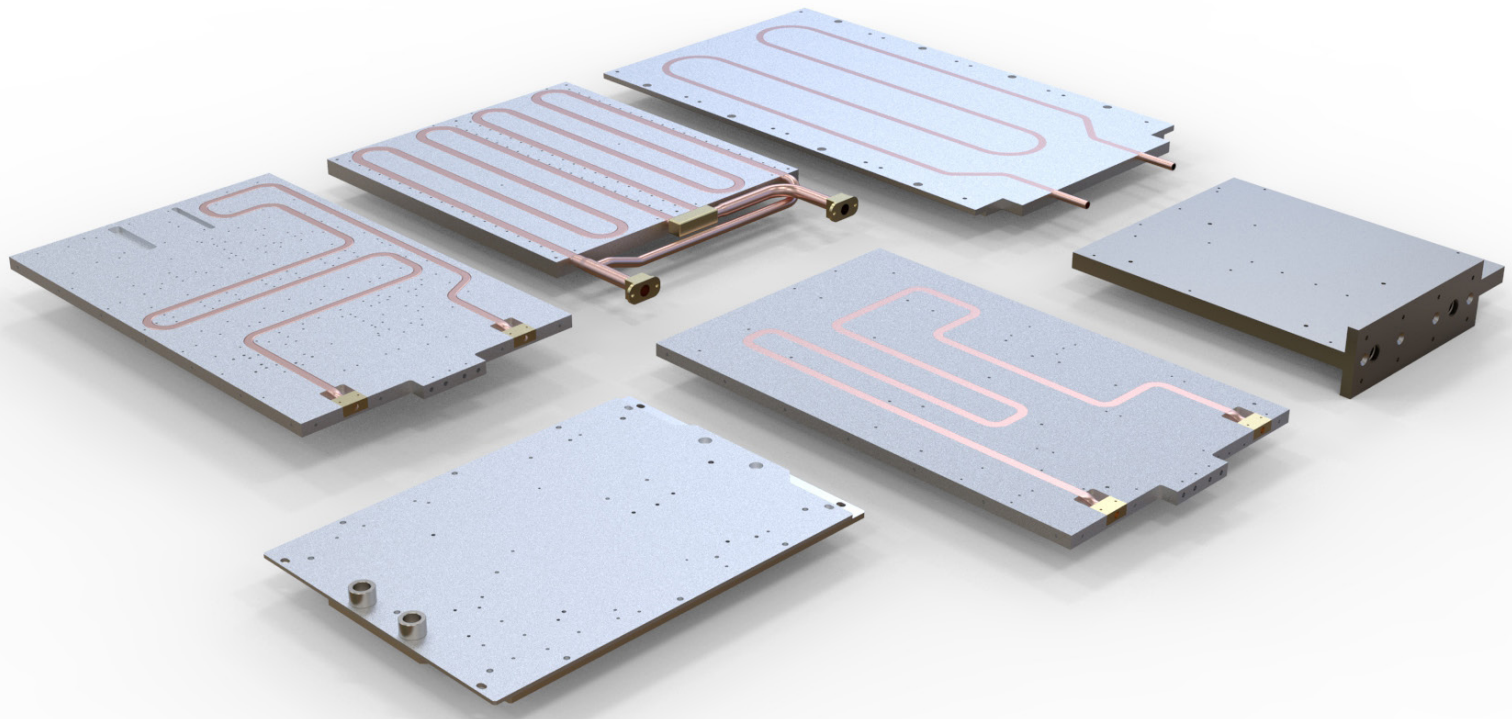

流体冷板 LCP (Liquid Cooling Plate)

冷板是一种单流体的热交换器，一般将冷板作为电子设备的底座。工作原理是通过空气、水、或其它冷剂等流体在通道中的强迫对流，将安装在冷板上的电子元器件或电子设备的热量带走。为了提高冷板的散热效率，冷板的通道中都会安装各种有效的肋片。因此在热流密度高，电子产品或设备的体积或质量受到严格限制的条件下，冷板具有优势。

Features & Benefits

- 材料采用高热导系数的铝或铜，如果元器件的位置分布适当，冷板的表面接近等温，可以带走较大的集中热载荷。
- 冷剂通过壁面吸收电子元器件的热量，两者之间不直接接触，可以避免冷剂对电子元器件的污染。
- 冷板采用间接冷却的方式，一般采用介电性能不好但传热性能优良的冷剂，比如：水 (e.g. not oxidizing acids, acids bases)
- 冷板通道的当量直径较小，通道中可以布置各种高效的肋片，因此冷板表面的传热系数高，目前流体液冷冷板的功率密度可以达到 $5W/cm^2$

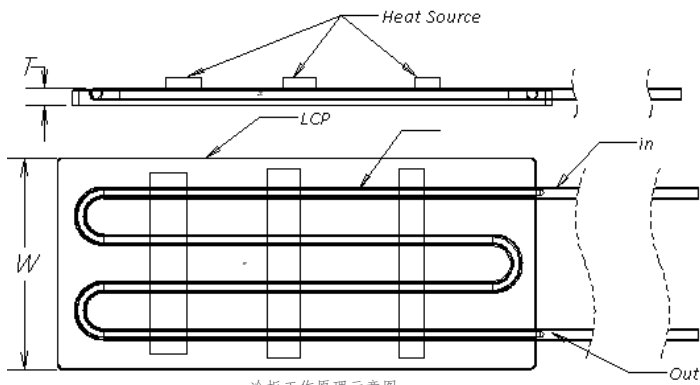

冷板工作原理示意图

常用冷却剂物性表

Fluid Type	Temperature °C	μ - 动力黏度 [Pa.s]	ρ - 密度 [kg . m ⁻³]	λ - 导热系数 [W · (m · k) ⁻¹]	比热容 [kJ · (kg · K) ⁻¹]	沸点 [°C]	冰点 [°C]
Water(水)	25 °C	896×10^{-6}	995	0.611	4.178	100	0
	60 °C	470×10^{-6}	982	0.654	4.178	100	0
FC75	25 °C	1441×10^{-6}	1757	0.064	1.038	101	-133
	60 °C	847×10^{-6}	1658	0.061	1.101	101	-133
coolanol 25	25 °C	4500×10^{-6}	900	0.132	1.884	179	-87
	60 °C	2450×10^{-6}	875	0.128	2.010	179	-87
coolanol 45	25 °C	17900×10^{-6}	890	0.135	2.010	179	-67
	60 °C	6960×10^{-6}	870	0.130	1.884	179	-67
Glycol-50	25 °C	1052	1052	0.423	3.516	105	-24
	60 °C	1029	1029	0.453	3.672	105	-24

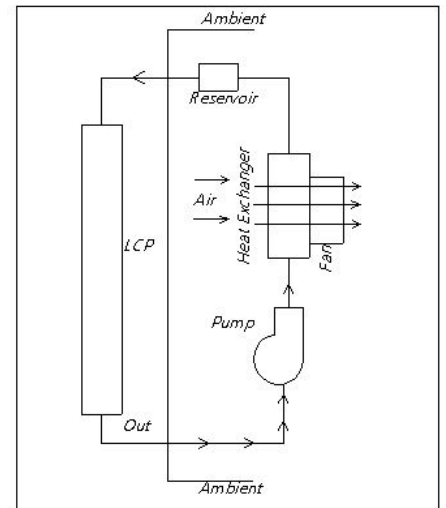

Liquid Cooling System

Extruded Cooling channels LCP [挤压流道冷板系列]
 EX - Series no: RX590-012-A1 Weight:3.14 kg/meter

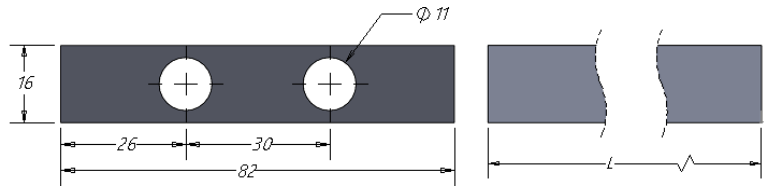
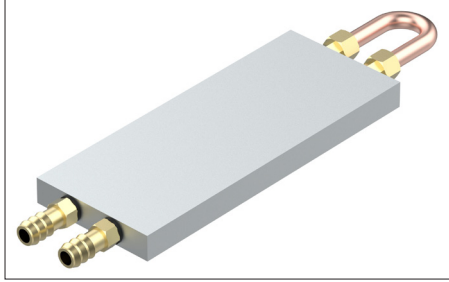

Extruded Cooling channels LCP [挤压流道冷板系列]
 EX - Series no: RX590-014-A1 Weight:6.68 kg/meter

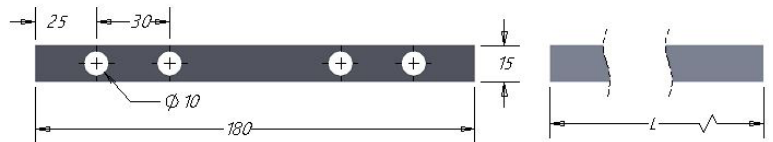
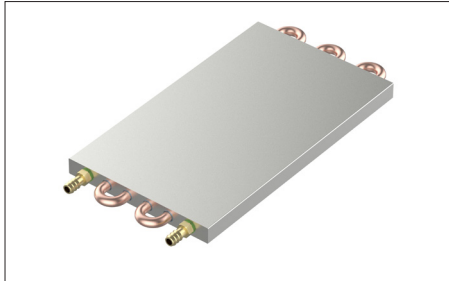

Extruded Cooling channels LCP [挤压流道冷板系列]
 EX - Series no: RX590-021-A1 Weight:5.13 kg/meter

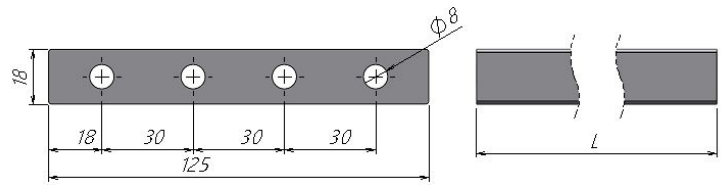

Extruded Cooling channels LCP [挤压流道冷板系列]
 EX - Series no: RX590-026-A1 Weight:20.8 kg/meter

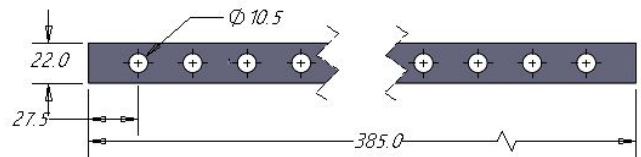
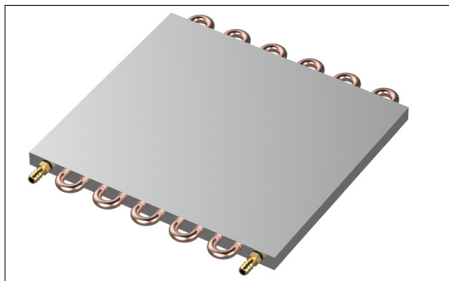

Pipe Cooling channels LCP [挤压流道冷板系列]
 EX - Series no: RX590-054-A1 Weight:12.8 kg/meter

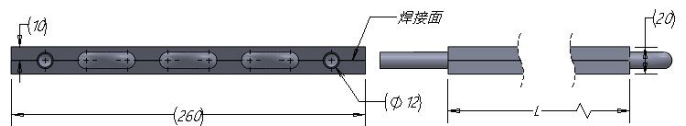

Pipe Cooling channels LCP [挤压流道冷板系列]
 EX - Series no: RX590-310-A1 Weight:1.82 kg/meter

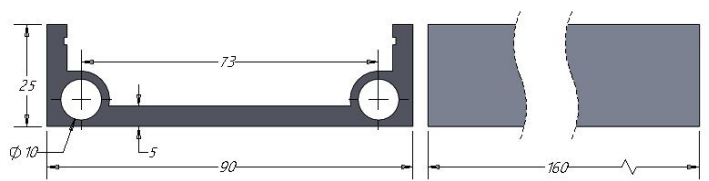
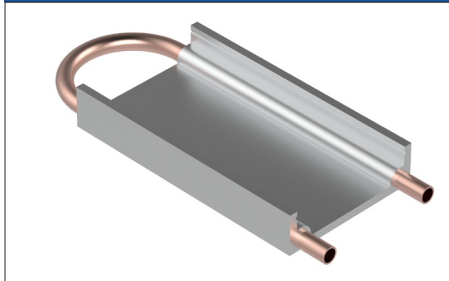

Extruded Cooling channels LCP [挤压流道冷板系列]
EX - Series no: RX590-322-A1 Weight:4.9 kg/meter

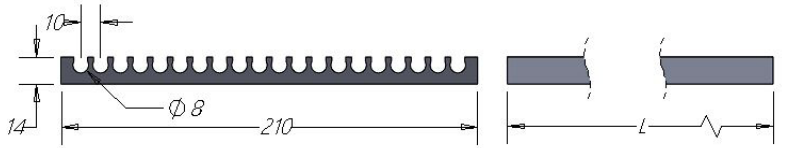
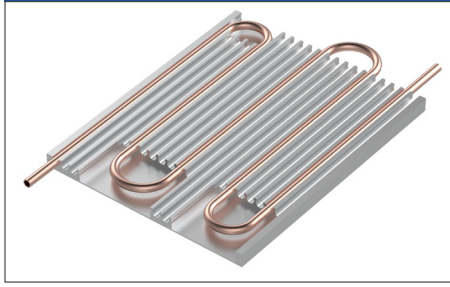

Liquid Cooling Plate- [流体散热系统]

冷板散热系统结构图

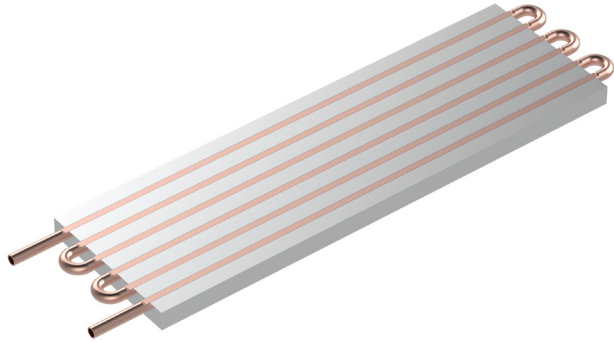
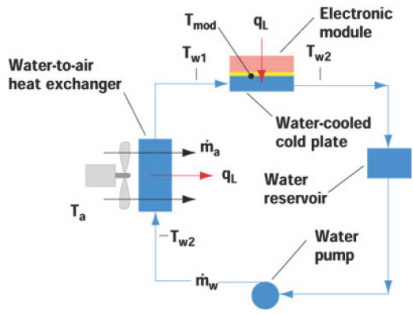

冷板管道附件连接的示意图

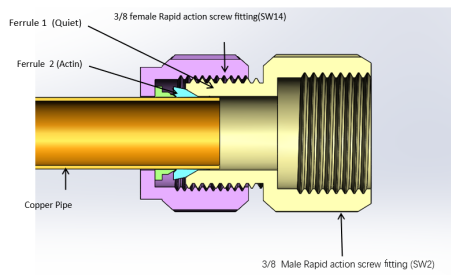

冷板各种管道附件的等效长度计算

附件类型	等效长度 [直径数]	附件类型	等效长度 [直径数]
45° 弯管	15	180° 弯管, 弯曲半径为 4 ~ 8 个管径	10
90° 弯管, 45° 斜接, 半径为 0	60	球形阀, 全开	300
90° 弯管, 弯曲半径为 1.0 个管径	32	闸阀, 全开	7
90° 弯管, 弯曲半径为 1.5 个管径	26	闸阀, 关闭 1/4	40
90° 弯管, 弯曲半径为 2.0 个管径	20	闸阀, 关闭 1/2	200
180° 弯管, 弯曲半径为 1.5 个管径	50	闸阀, 关闭 4/4	800

冷板的压降计算

$$\Delta P = \Delta P_1 + \Delta P_2 + \Delta P_{CF} - \Delta P_2$$

Copper Pipe Cooling channels LCP [铜管流道冷板系列]
CP - Series no: RX615-022-19

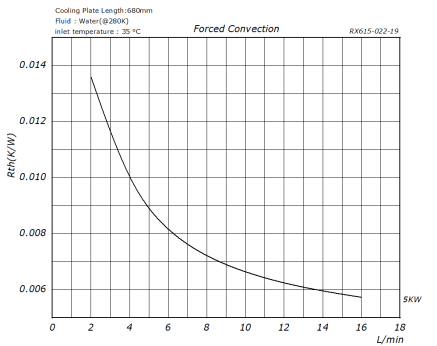
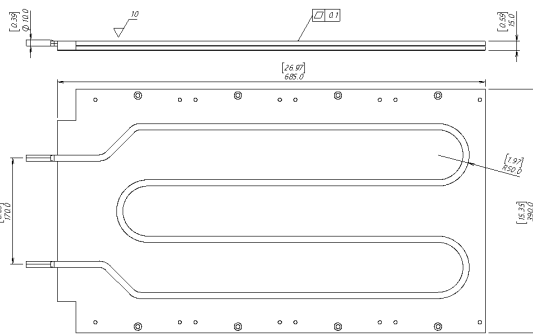
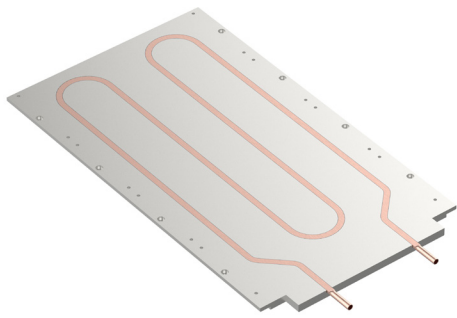

Copper Pipe Cooling channels LCP [铜管流道冷板系列]
CP - Series no: RX615-171-19

