Company Profile

Shaping the future together — your partner for thermal management solutions in renewable energy

CONTENT

01

Company Profile

02

Products

03

Applications

04

Competencies

Part - 01

Company Profile

Overview

Established
Nov - 2013

Industry-Leading Thermal Management Solution Provider

主营产品
Business Scope

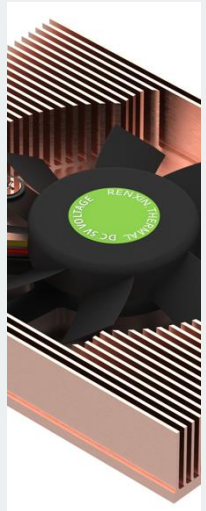

Skived Fin

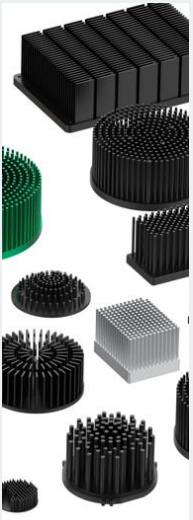

Forging

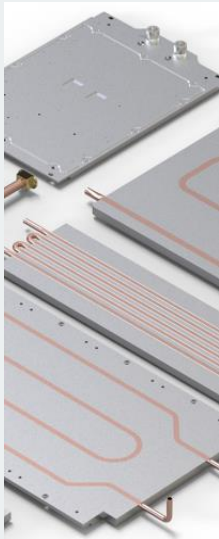

LCP

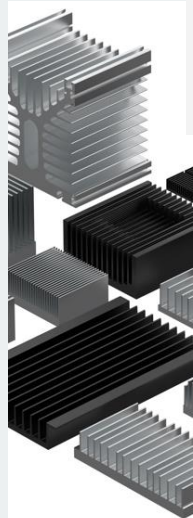

Extruded

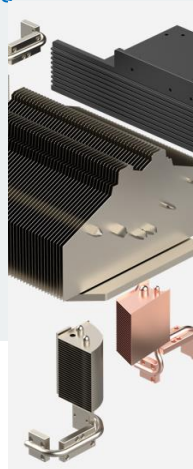

Heat Pipe



Housing



Assembly

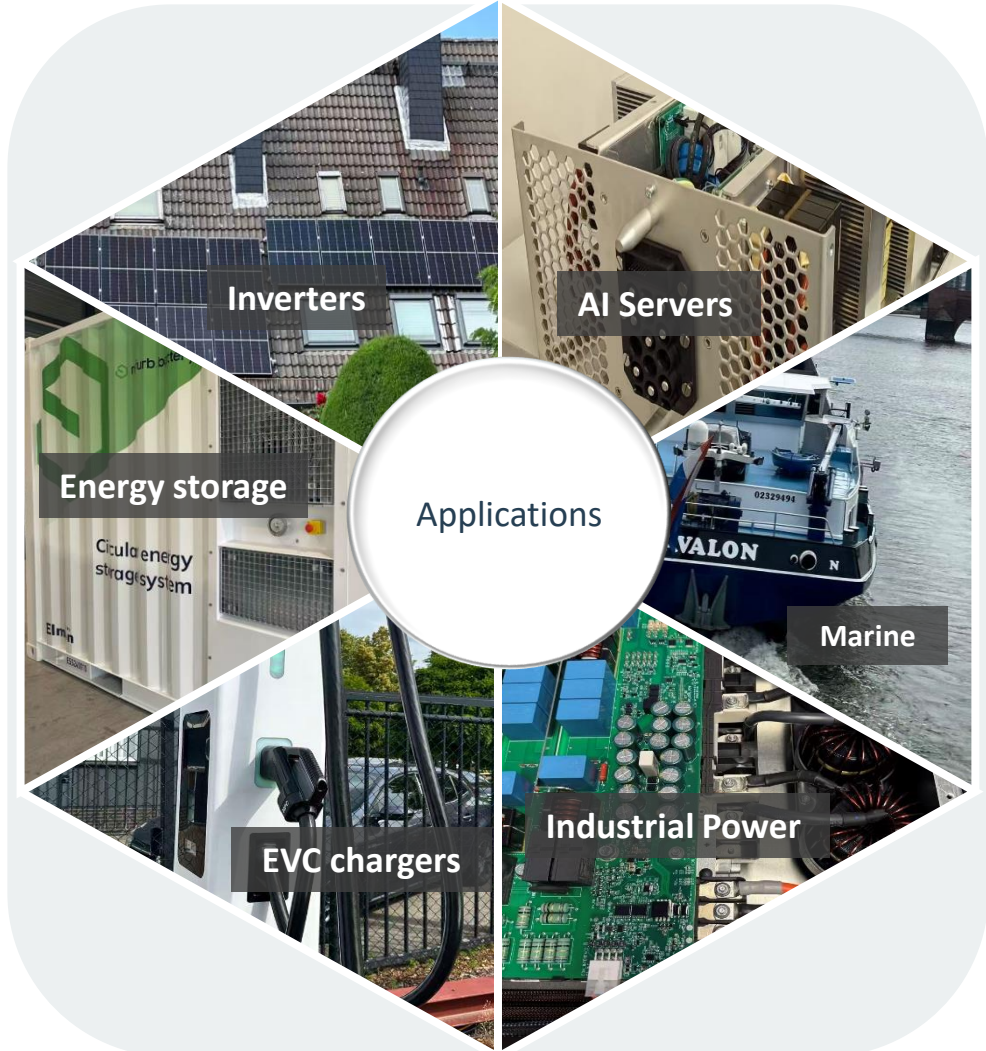

Address

Factory Address : #23 Weijian Road, Zone E, Weijian Industrial Park,
Chashan Town, Dongguan City, Guangdong Province, China



广东省东莞市茶山镇伟建工业区伟建路E区30号

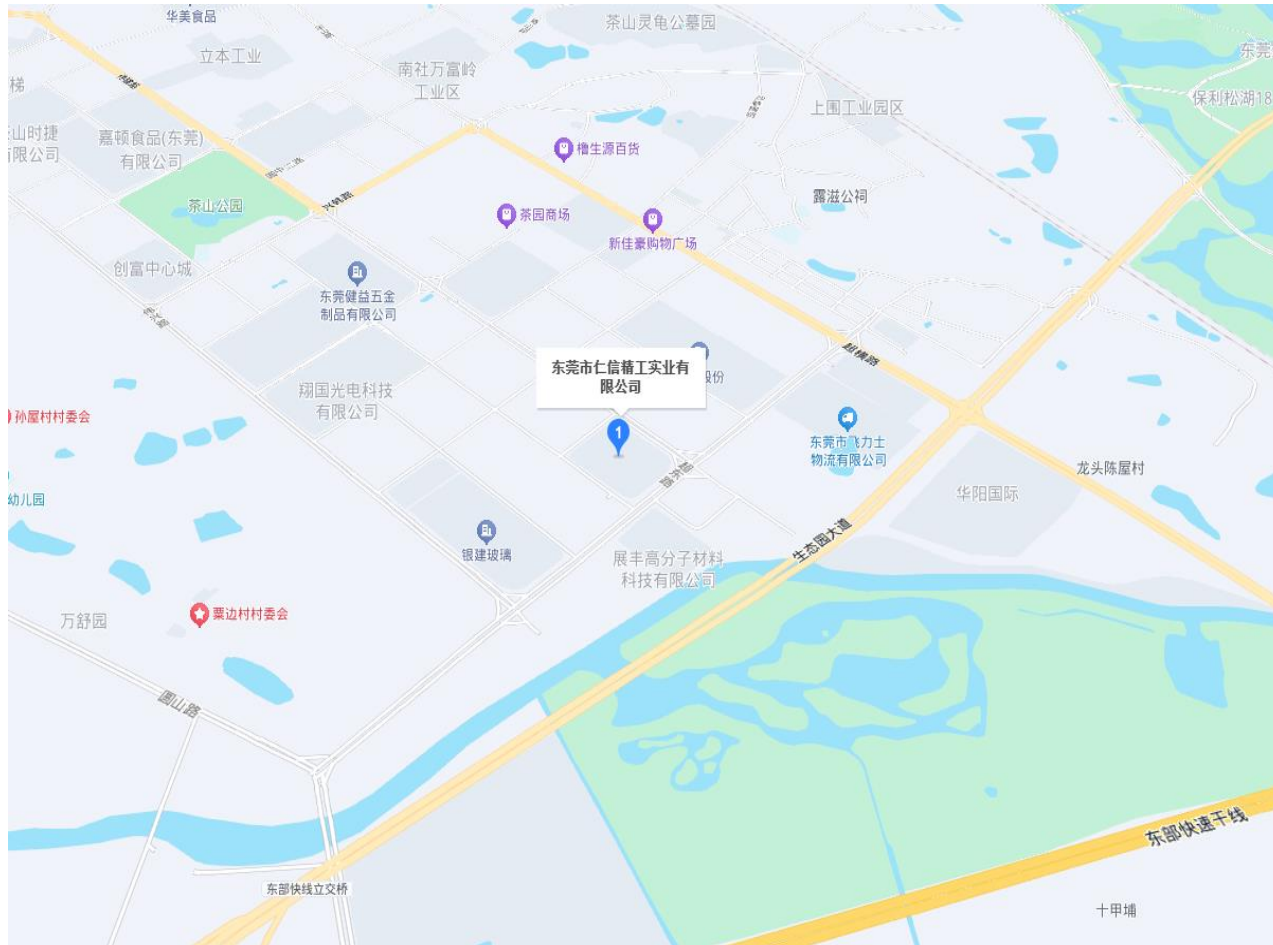

Dongguan is located in the heart of the Guangdong-Hong Kong-Macao Greater Bay Area and is recognised as one of the world's key manufacturing hubs. Supported by a well-established industrial ecosystem, mature supply chain network, and efficient international logistics infrastructure, Dongguan offers global customers reliable and efficient manufacturing and business cooperation advantages.

Our company is located at No. 23, Zone E, Weijian Road, Weijian Industrial Park, Chashan Town, Dongguan. The location offers excellent transportation access, with direct connections to Dongbu Expressway and Ecological Park Avenue just outside the facility. The Pearl River Delta Ring Expressway and Congguan-Shenzhen Expressway are both within 5 km, while Shenzhen Bao' an International Airport is approximately 63 km away.

The surrounding area provides a convenient and comfortable environment for both work and daily life, with nearby supermarkets, night markets, rental apartments, Chashan Park, and Dongguan Ecological Park, offering a good balance of business convenience, leisure, and living amenities.

Global Footprint

Global Presence (3)

- Renxin-Seiko Industry Co., Ltd
- Renxin Seiko (Hong Kong) Limited
- Renxin Seiko(Thailand) Co., Ltd

R&D Center (1)

- Dongguan

Global Sales Network

- 东莞 (Dongguan)
- 深圳 (Shenzhen)
- 曼谷 (Thailand)
- 荷兰 (Netherlands)
- 德国 (Germany)
- 西班牙 (Spain)
- 加拿大 (Canada)
- 巴西 (Brazil)



Development History

March 2015
Established
manufacturing
launched CNC machining

Secured Orders from Daikin and Hitachi

December 2022
Established Sheet
Metal Division

April 2023 Established Thailand Subsidiary

Core Values: People First、 Integrity & Trust、 Commitment to Excellence、 Dedication and Perseverance

November - 2013
Company Established

Deliver comprehensive thermal management solutions, including prototype development, tooling design, and product structural engineering services

September 2016
Expanded Manufacturing
Facility

2017 Established the Shenzhen branch and was officially recognized as a National High-Tech Enterprise

September 2025 Expanded
Manufacturing Capacity

2025 Awarded "Specialized and Innovative Enterprise" Recognition and Became a Siemens Supplier

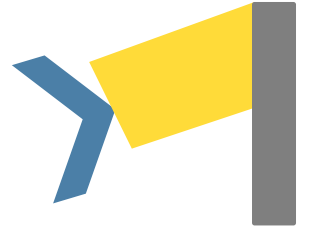

Company Overview



Dongguan Factory



- ◆ #30 Weijian Road, Zone E, Weijian Industrial Park Chashan Town, Dongguan City, Guangdong China
- ◆ Production Area : 5100 m²
- ◆ Production Start Date : 2016



Thailand Factory



- ◆ BAN HUA KROK Bangkok Chonburi Motorway
- ◆ Production Area : 2100 m²
- ◆ Production Start Date : 2023

Competencies



Technology

研发能力

热方案和产品结构设计整体解决方案

- 热方案设计
- CFD热仿真
- 热功能测试
- 实验室
- CAD设计
- CAE仿真
- 模具设计
- 模流仿真

技术团队 技术人员占比25%

- 热设计工程师 3 人
- 结构工程师 2 人
- 钣金工程师 3 人
- CNC 工程师 7 人

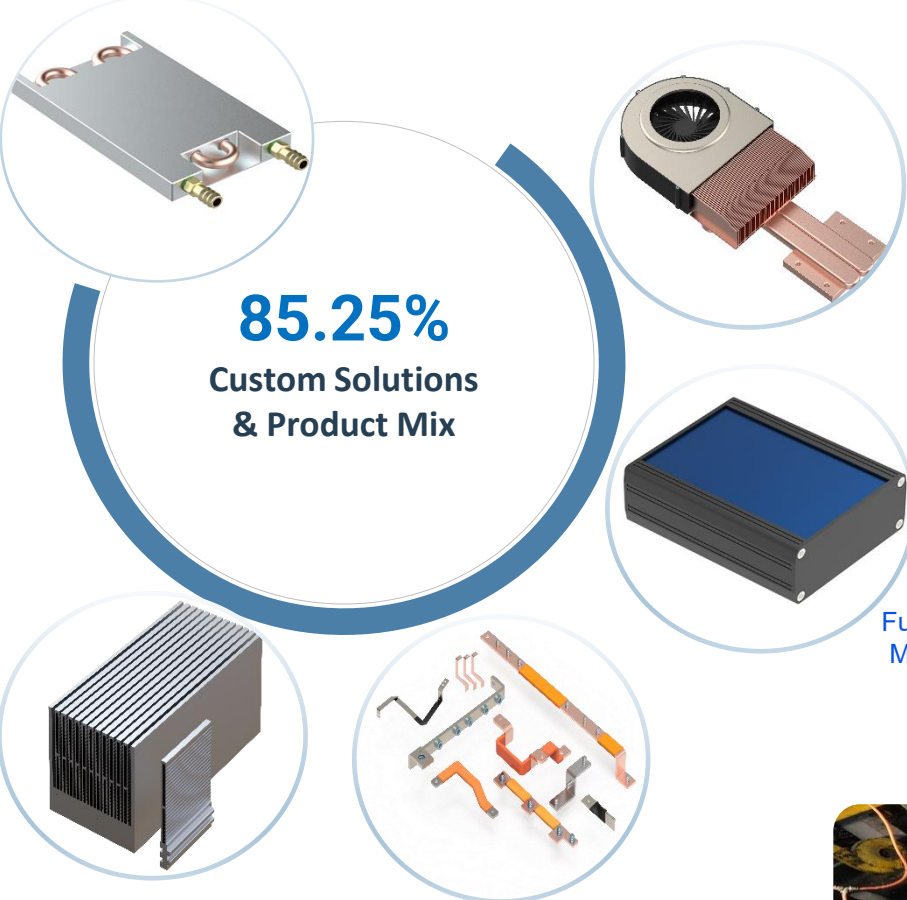

Intellectual Property & Patents

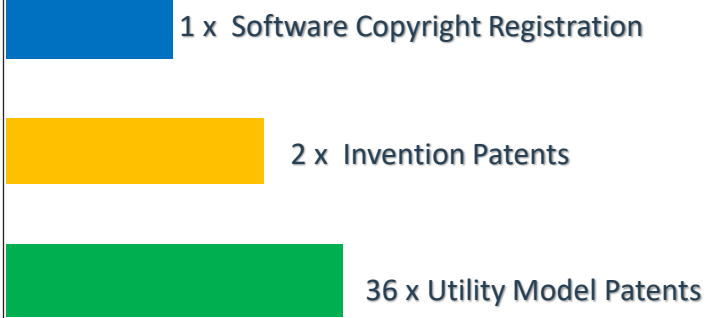

Competencies

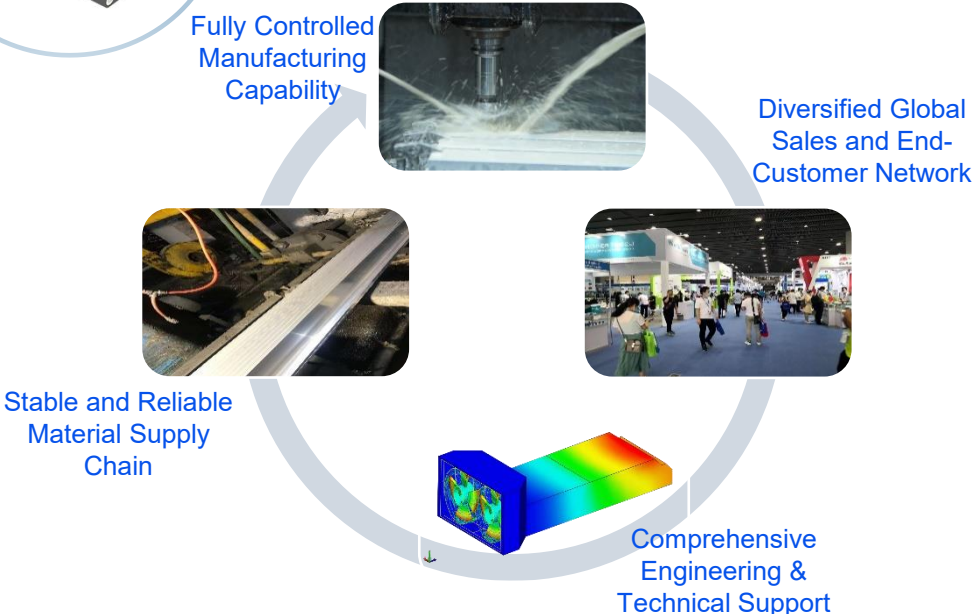

Certifications & Qualifications

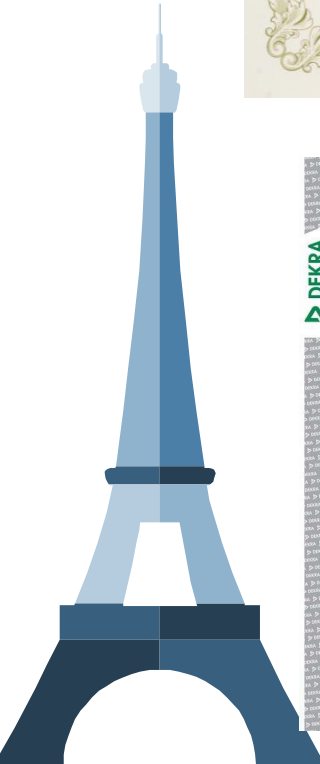
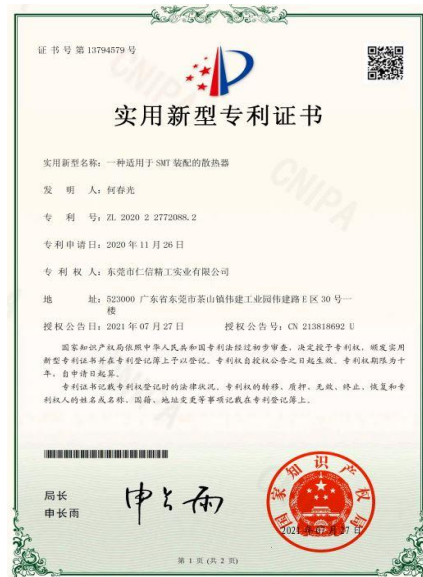
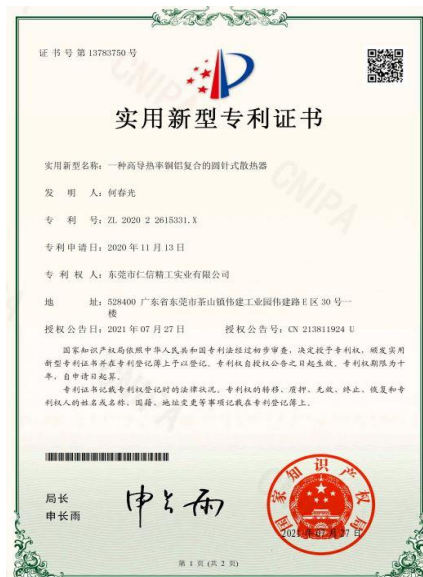
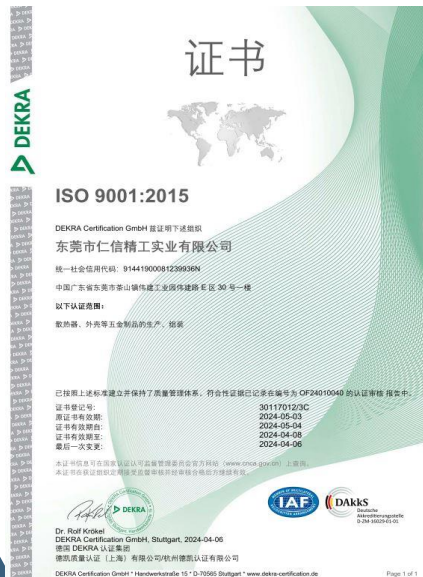
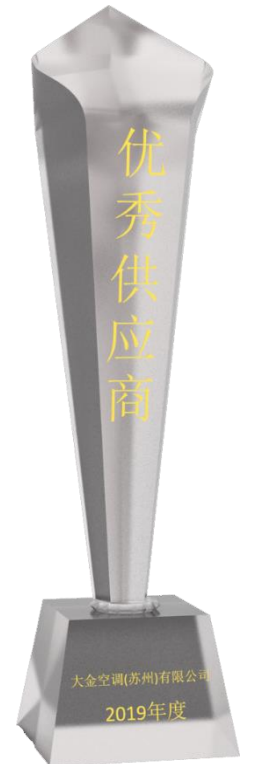
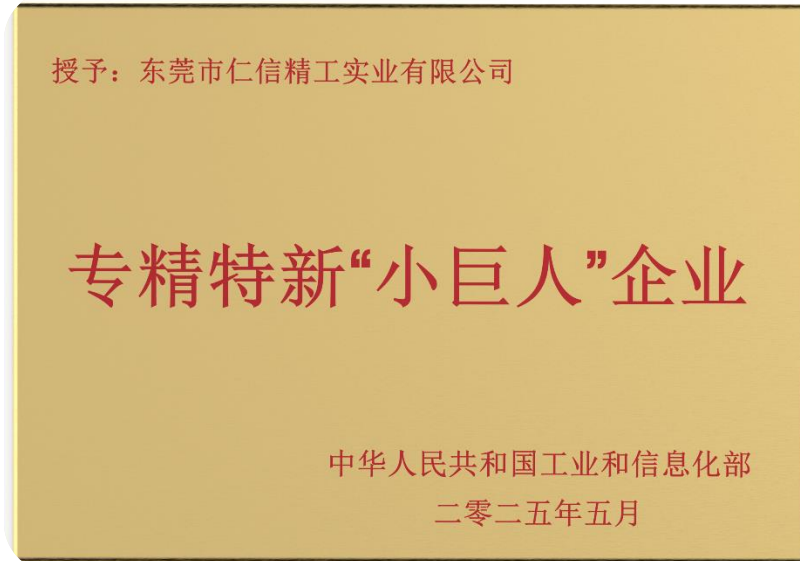

R&D Capabilities and Manufacturing Facilities



Thermal Testing & R&D Lab



CNC Machining Workshop



Skiving & 5-Axis CNC Machining Facility



CNC Precision Cutting Facility



Sheet Metal Fabrication Facility



Assembly & Packaging Facility

R&D Capabilities and Manufacturing Facilities



30T CNC Press Brake



Servo Riveting Equipment



Punch Press



Laser Welding Machine



CNC Tube Bending Machine



Vacuum Brazing Furnace

R&D Capabilities and Manufacturing Facilities



Bystronic 1200W Laser Cutting Machine



Bystronic 80T CNC Press Brake



CNC Precision Skiving Machine



5-Axis CNC Machining Center

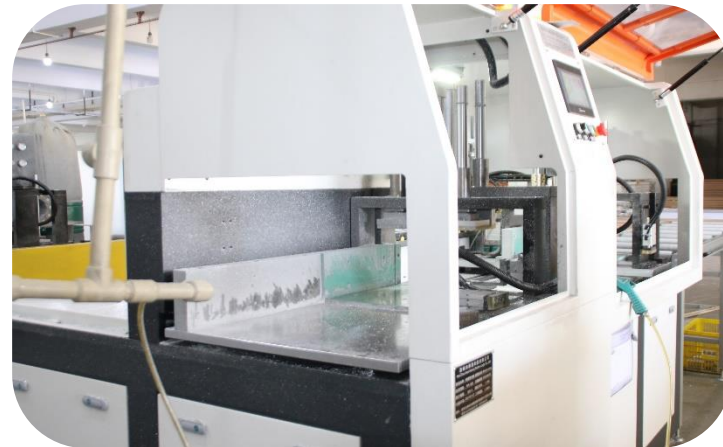

CNC Automatic Precision Cutting Machine



Ultrasonic Cleaning System

Quality Assurance Capabilities



Quality Inspection Room 1



Quality Inspection Room 2

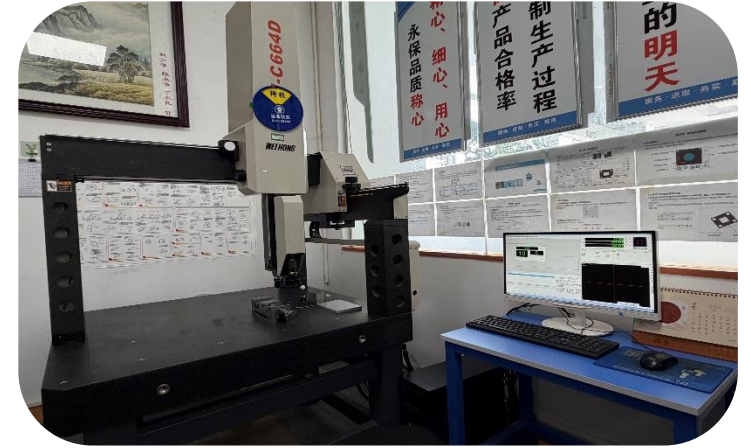

600 x 500 x 400 CMM



Vision Measuring System



UV Weathering Test Equipment



Temperature & Humidity Test Chamber

Quality Assurance Capabilities



X-Ray EDXRF Spectrometer



Light Transmittance Tester



Thermal Testing Platform

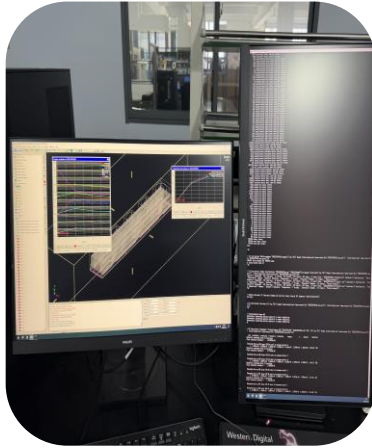

CFD Simulation Server



Scanning Inspection Equipment



Klein Colorimeter



Koslow Passi Flash Passivation Tester



Surface Roughness Tester



Mitutoyo Digital Micrometer



Koslow Aluminum Passivation Tester

Quality Assurance Capabilities



Mitutoyo Digital Height Gauge



Silk Screen & Etching Inspection Magnifier



Silk Screen Cross Hatch Adhesion Test



High Voltage & Insulation Resistance Testing



Mitutoyo Bore Gauge



Push-Pull Force Gauge



Shore Hardness Tester



Leeb Hardness Tester



Torque Tester



Coating Thickness Gauge

Quality Assurance Capabilities



Salt Spray Test Equipment



Pin Gauge

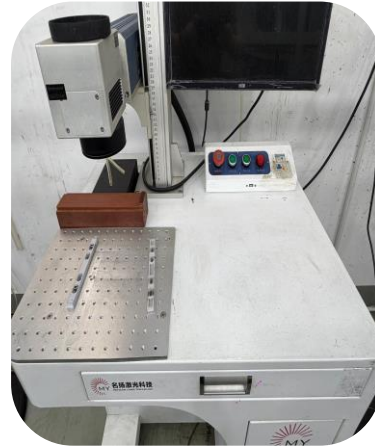

Laser Marking Machine



Leak Testing Equipment

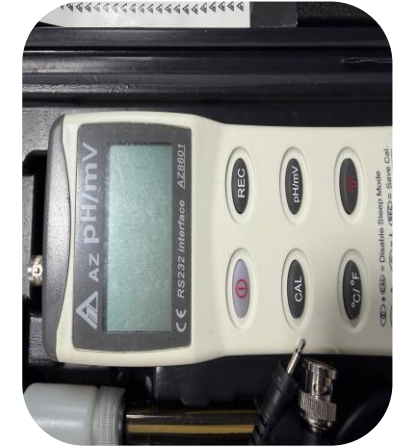

pH Meter



Digital Megohmmeter



LCR HiTESTER

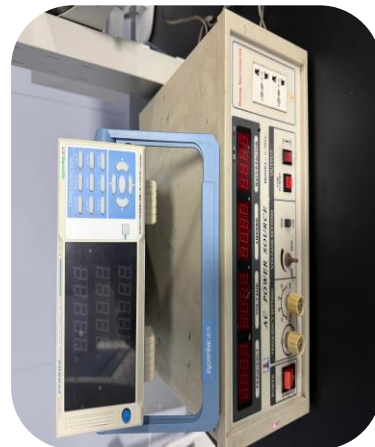

High Voltage Insulation Tester



Thermal Imaging Camera



Flaw Detection Tester

Organization Chart

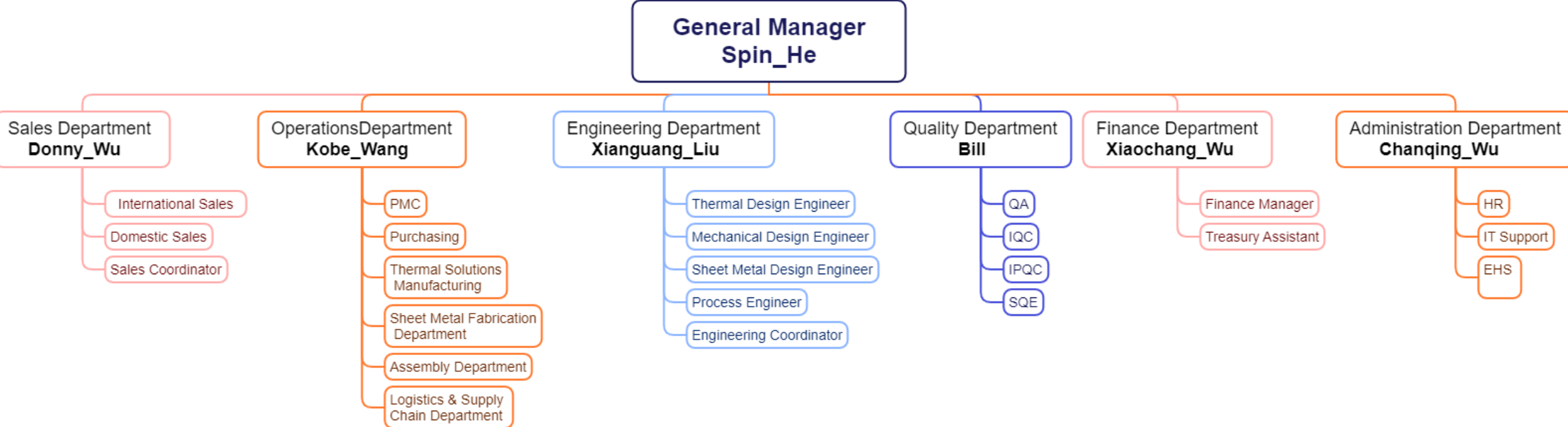

2020~2025 Annual Revenue

2020 ~ 2025 Annual Revenue

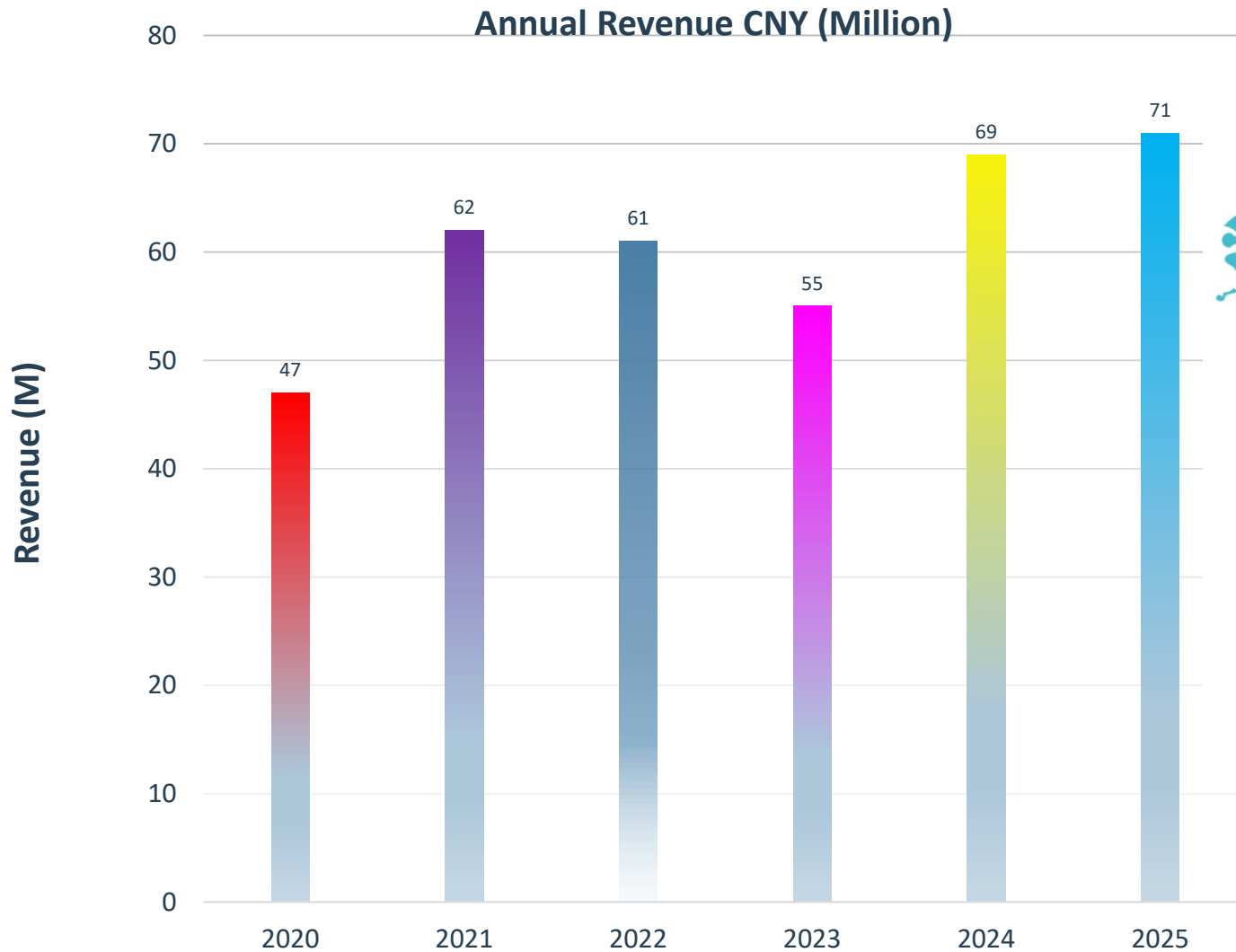

Market Distribution



- Europe** – Core market with long-term partnerships in industrial and EV applications
- Asia-Pacific** – Strong manufacturing base and regional customer support
- North America** – Developing market with increasing project opportunities
- Global Expansion** – Continuously expanding presence across key international markets

Employee Life & Welfare



Reception Area



Pantry / Refreshment Area



Workshop Break Area



Office

Employee Life & Welfare

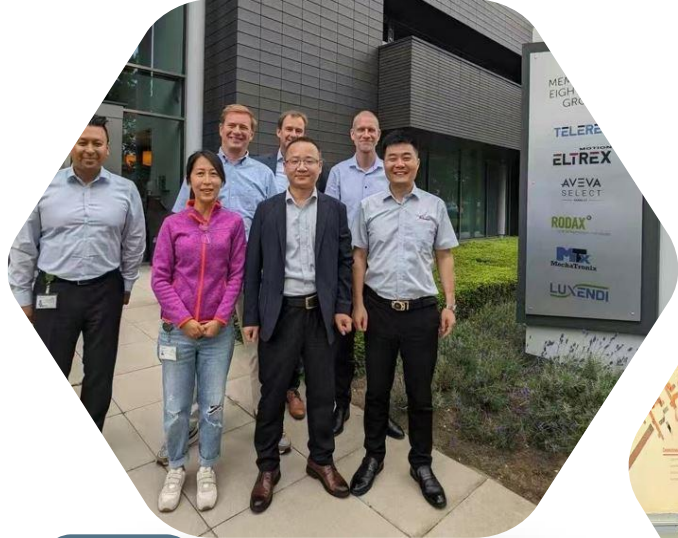

Telerex Visits

超越



Company Events



Munich Trade Fair

开拓



Customer Visit

创新



CTX Visits

引领

合作伙伴

Strategic Partners

SIEMENS

 NORTEK CONTROL

 Banking
广电运通

TELEREX

 MSB
Gerätetechnik GmbH

flex

 DAIKIN

 CTX
THERMAL
SOLUTIONS

ASML

 PRODRIVE
TECHNOLOGIES

 SUNWODA
欣旺达

HITACHI

amec

 REHM
Welding Technology

 堅田電機株式会社
KATATA ELECTRIC CO.,LTD.

 紫光展锐
UNISOOC

 FOXCONN®
富士康科技集团

 FLYING
POWER SUPPLY

 PART DESIGN

 inelmatic
electronics

HeT 和而泰

 bp
chargemaster 

 LUNDS

 heliox
A Siemens Business

 ADB
SAFEGATE

Part - 02

Products

Product Portfolio

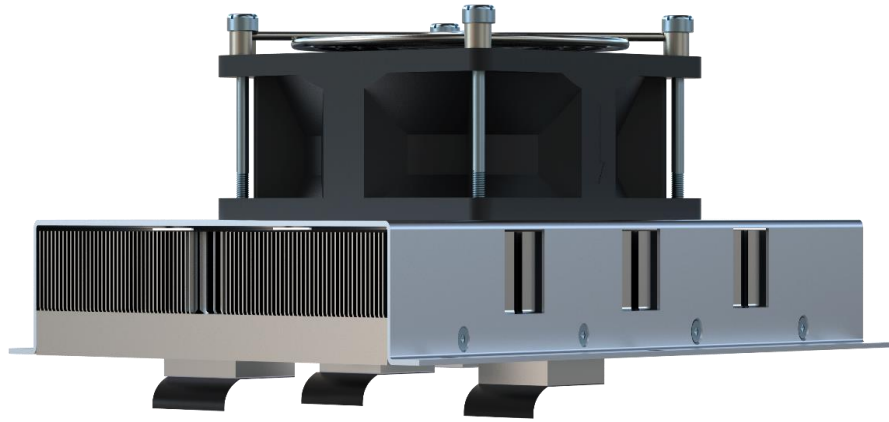

Skived Heatsink

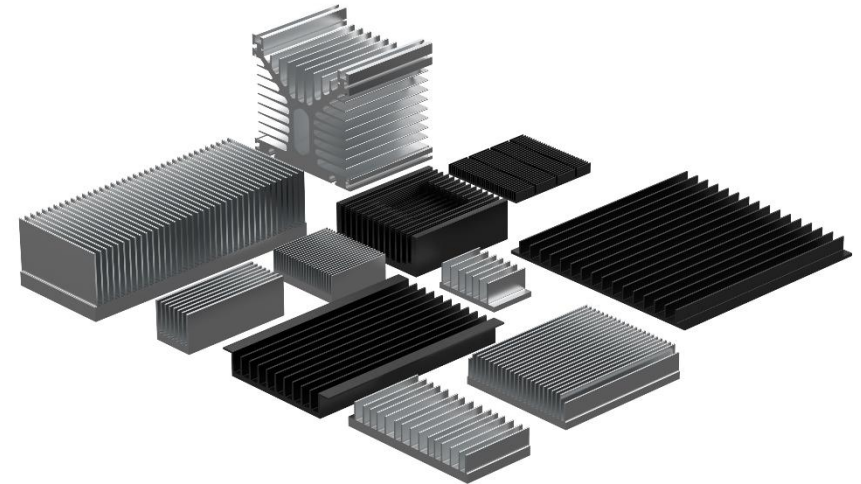

Extruded Profiles Heatsink

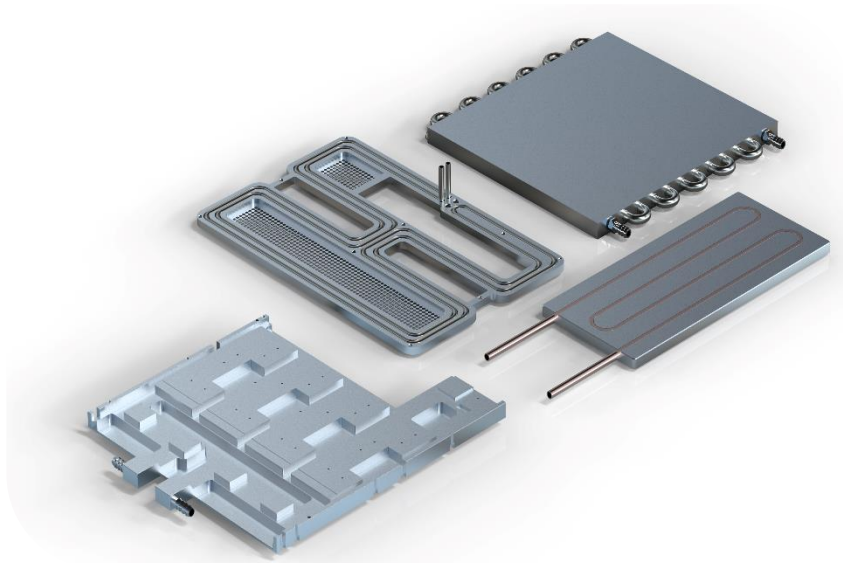

Liquid Cold Plates



Cooling Aggregates

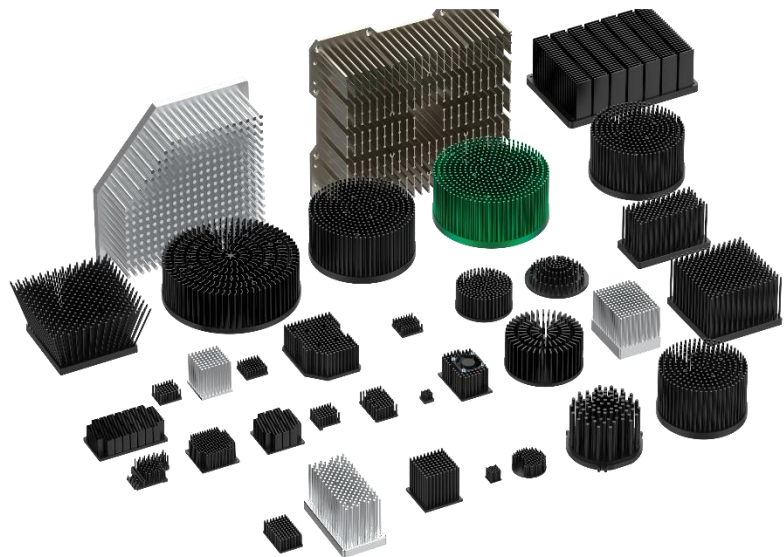

Forging Heatsink

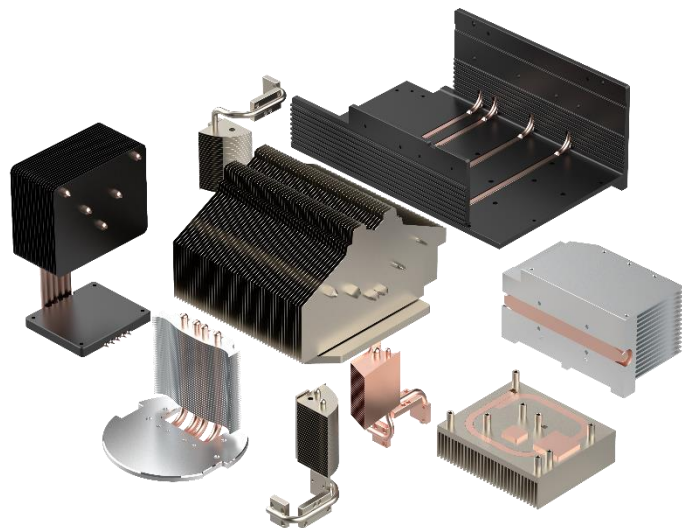

Heat Pipe

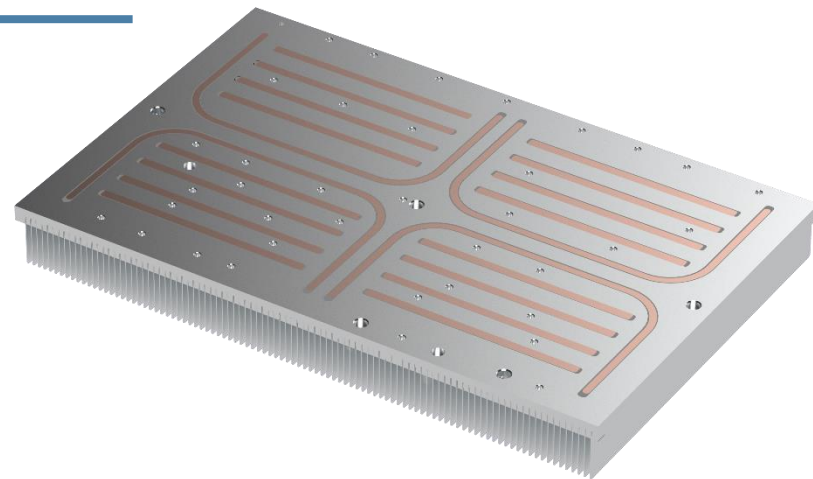

Stacked Fin



Extruded Profiles Case

Product Portfolio

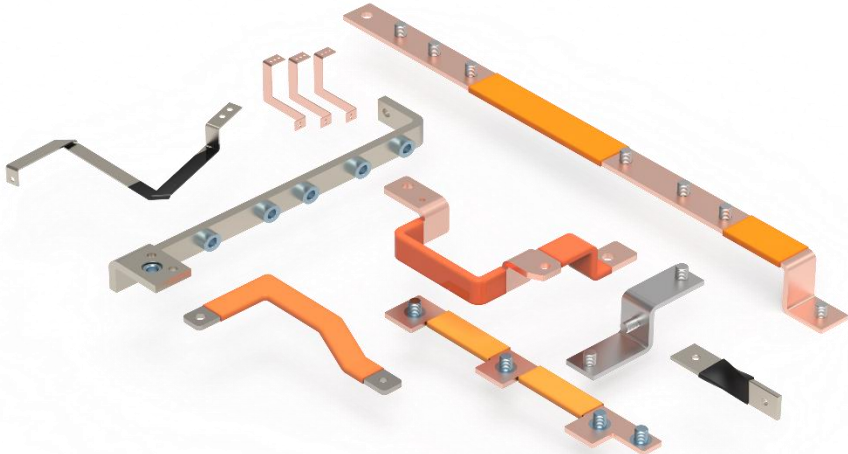

Busbar & Felix Bar

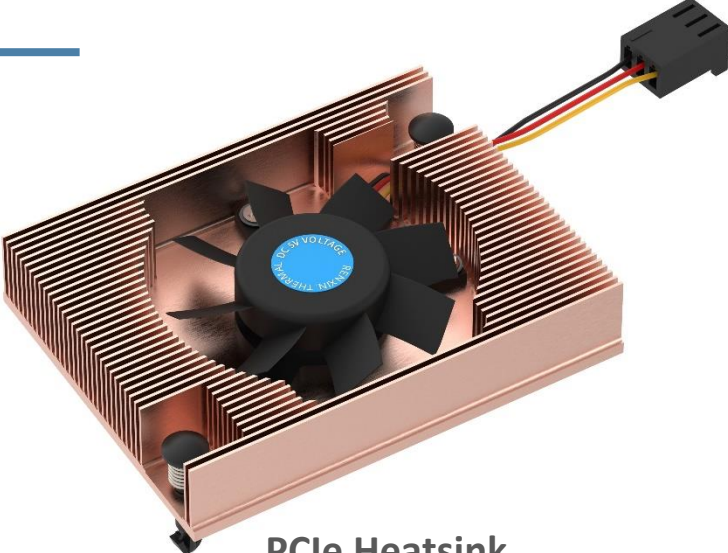

PCIe Heatsink

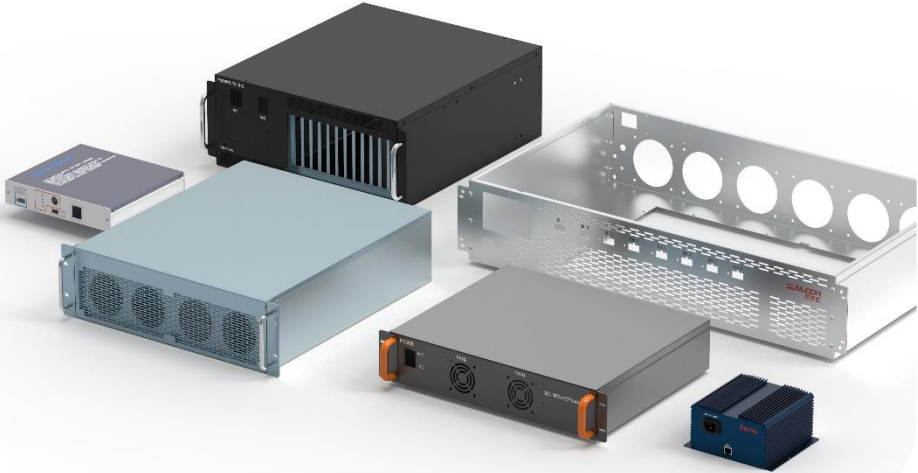

Sheet Metal Fabrication Parts



CNC Machining Services

Products & Flow Chart

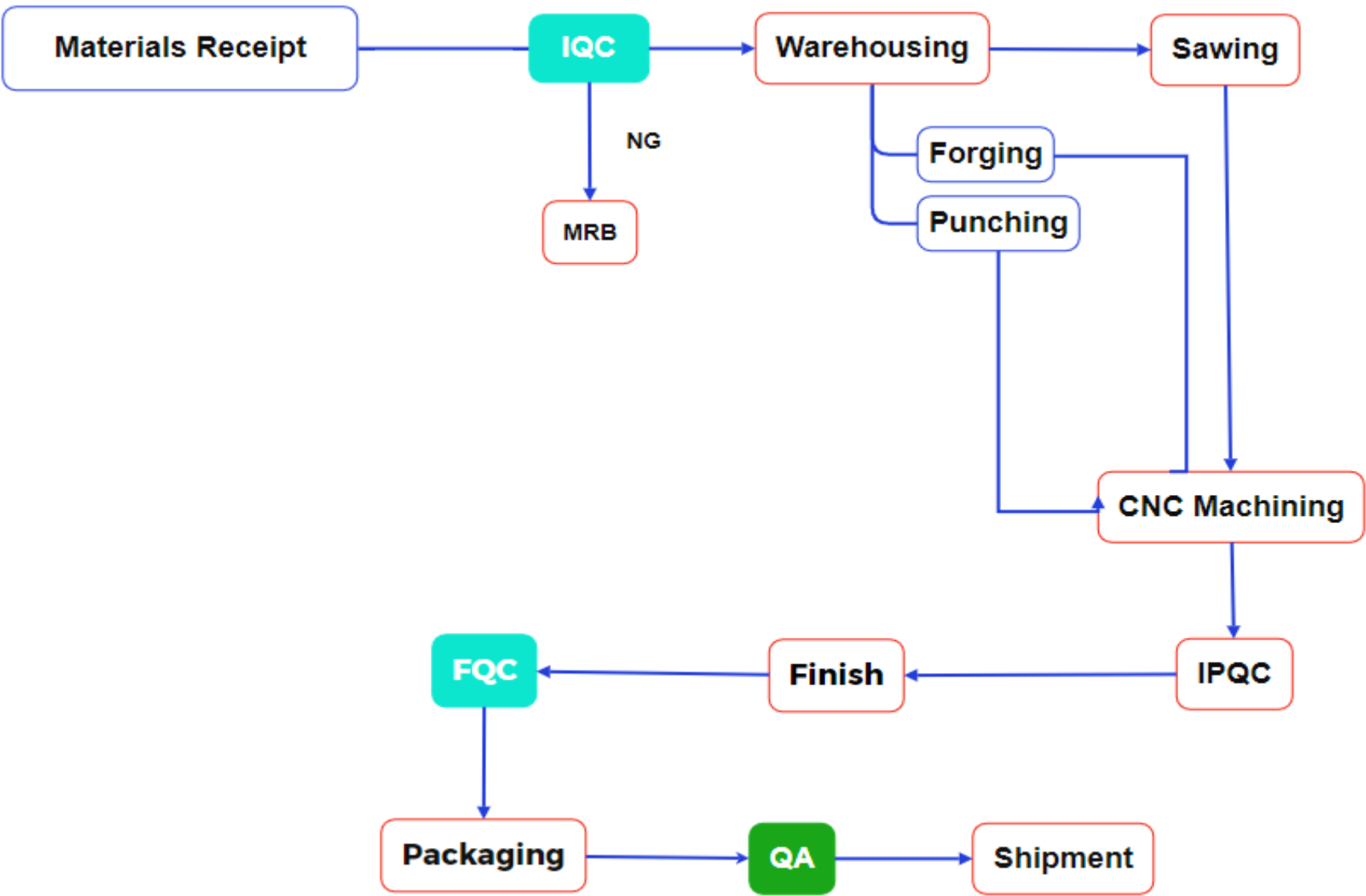

Part - 03

Applications

Industry Applications



Industrial Power Supply

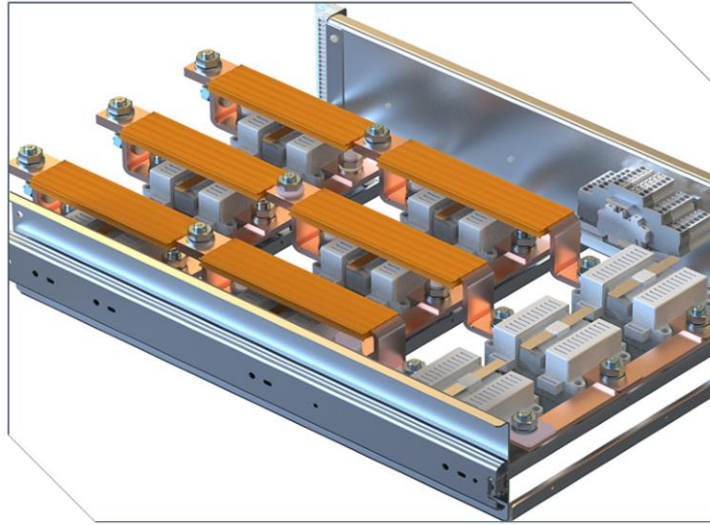

Power Equipment

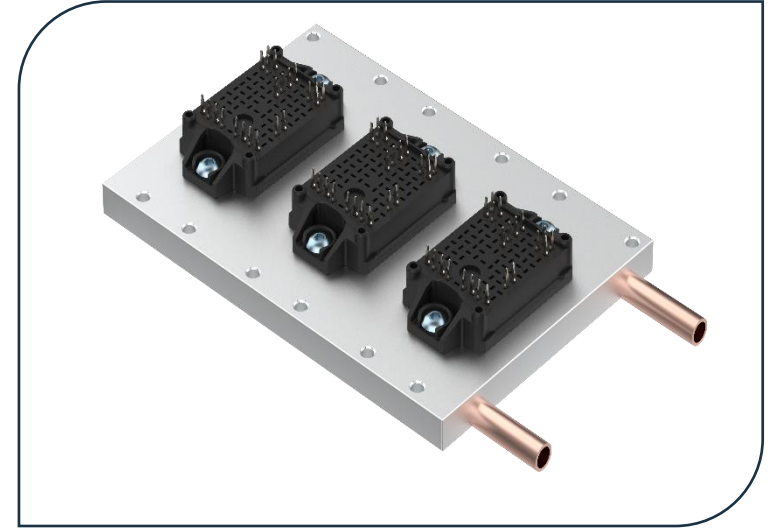

IGBT Cooling



High-Power Relay



Marine Equipment

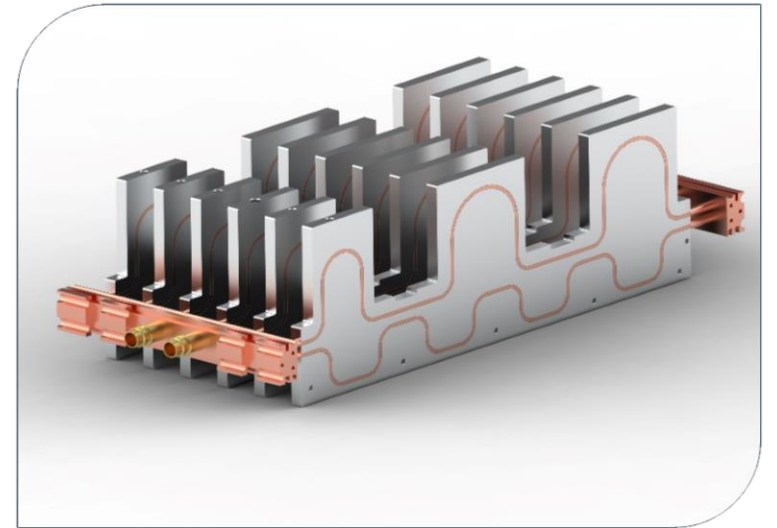

AI Server

Industry Applications

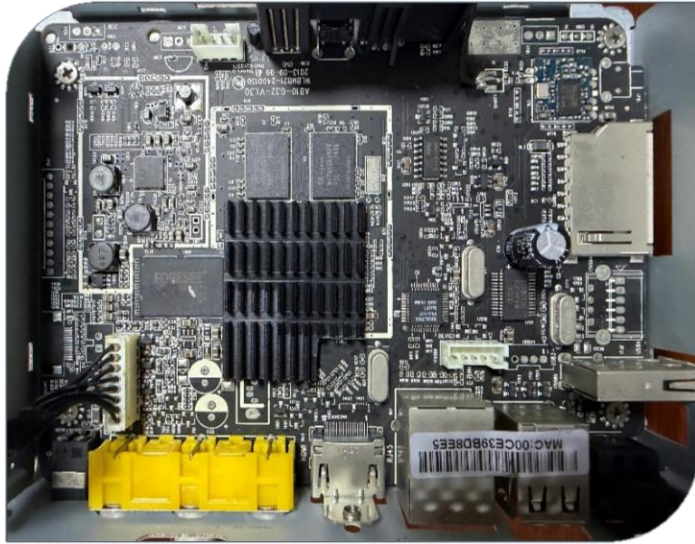

Motherboard Cooling

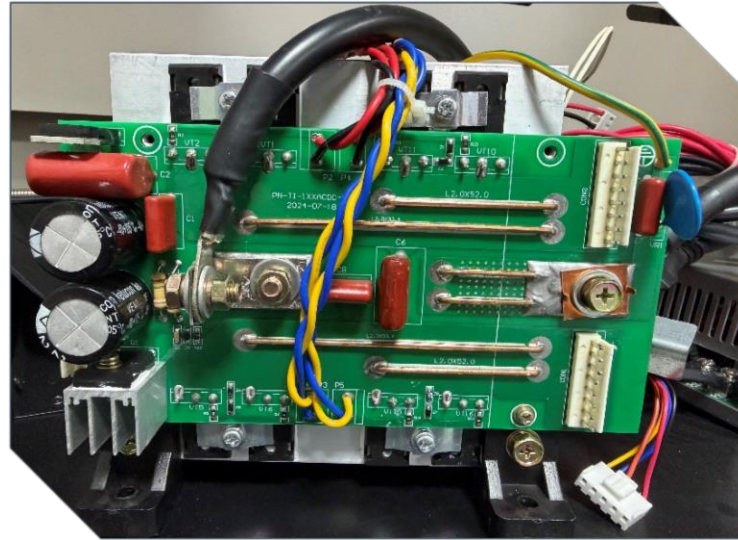

Welding & Automation Equipment



EV Charging Station



Inverter

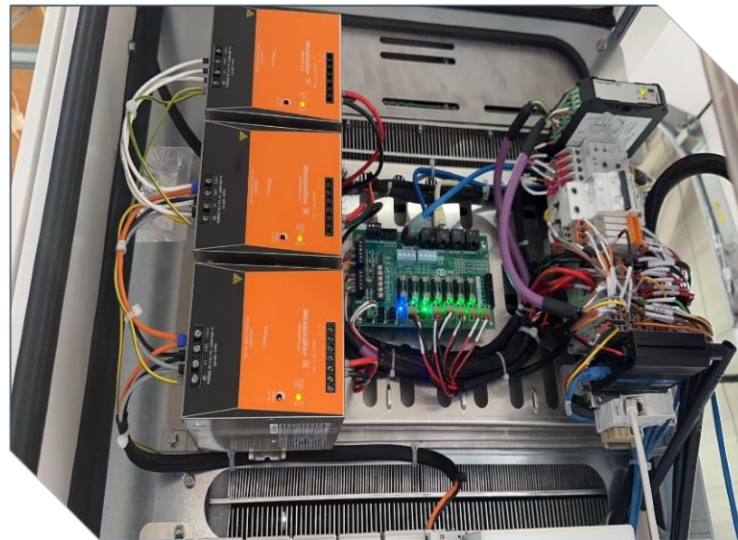

Medical Equipment



Battery Energy Storage

Part - 04

Competencies

Competencies

1. Strong Engineering & Thermal Design Capability

Advanced expertise in thermal management, including simulation (CFD / ICEPAK) and DFM optimization to ensure efficient and reliable designs

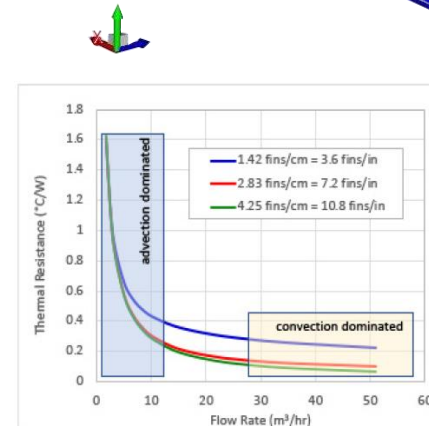
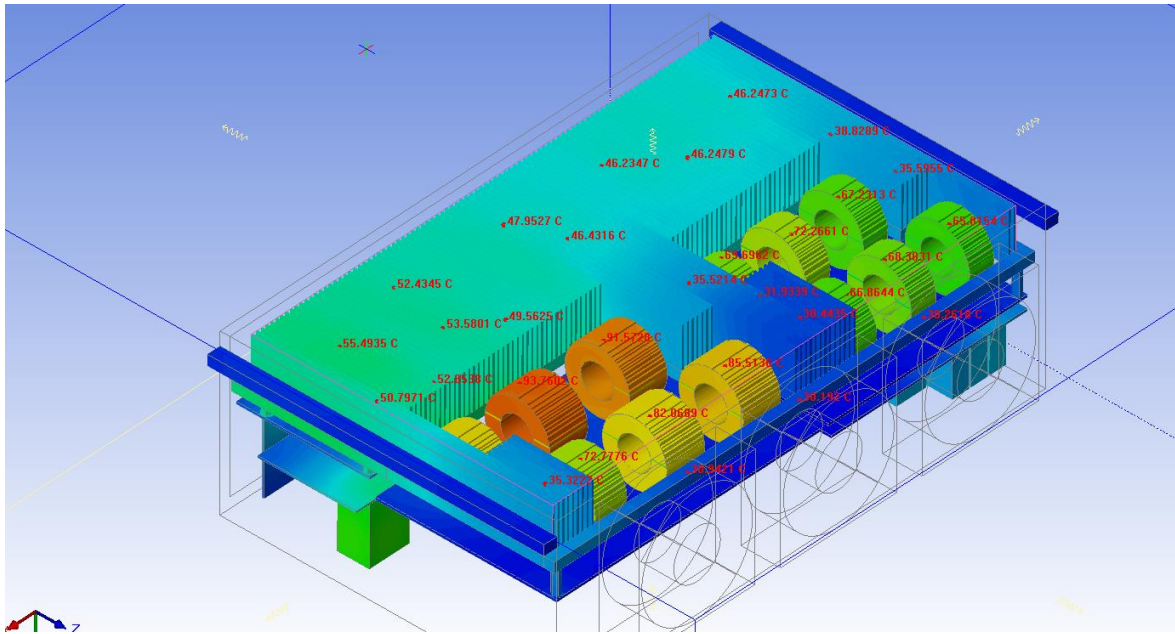
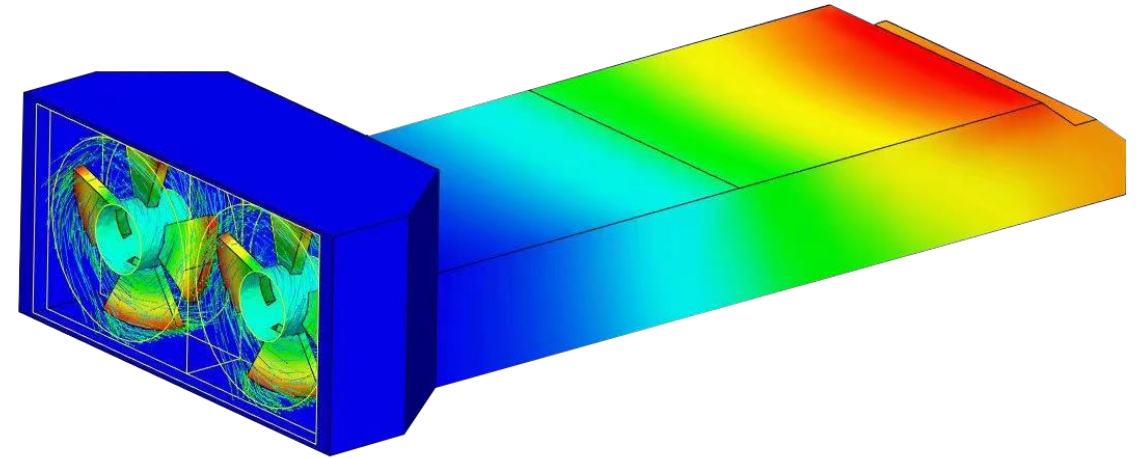
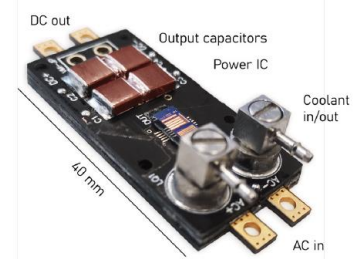
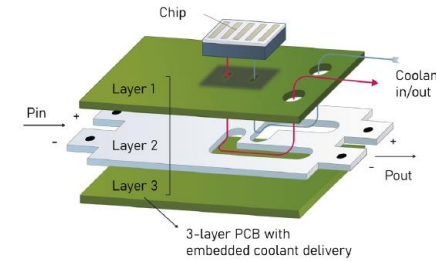

Figure 1: Example of the effects of flow rate and fin geometry on the thermal resistance of a heat sink

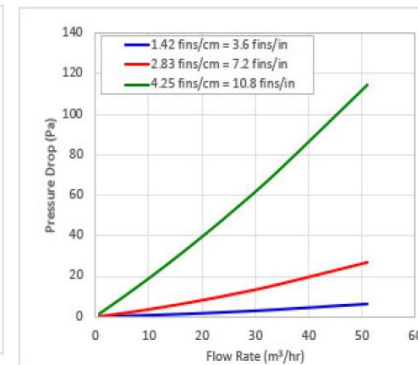

Figure 2: Pressure drop through different heat sinks as a function of flow rate

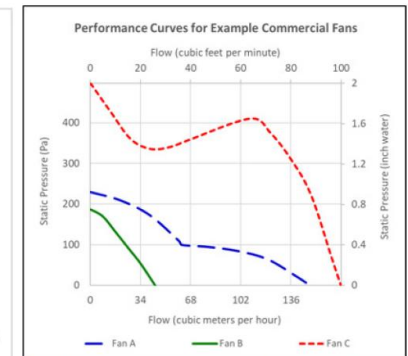
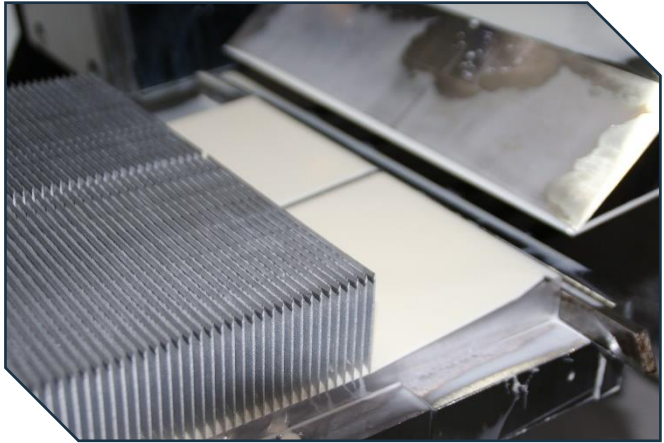

Figure 3: Fan performance curve for three commercial fans operating at 24VDC, as reported by manufacturers

Competencies

2. Integrated Manufacturing Capability

In-house CNC machining, sheet metal fabrication, and assembly, enabling fast turnaround and consistent quality



Competencies

3. Robust Quality Assurance System

Full compliance with international standards (RoHS, REACH, UL) supported by FAI, traceability, and process control

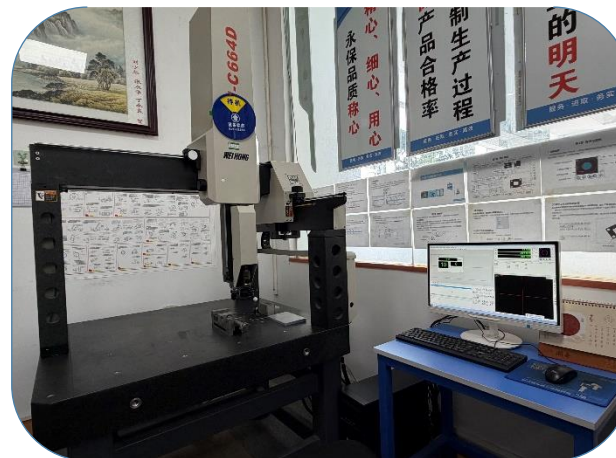

Success Always Belongs To Those Prepared!

Thank You
