

2	1
Versions	Notes

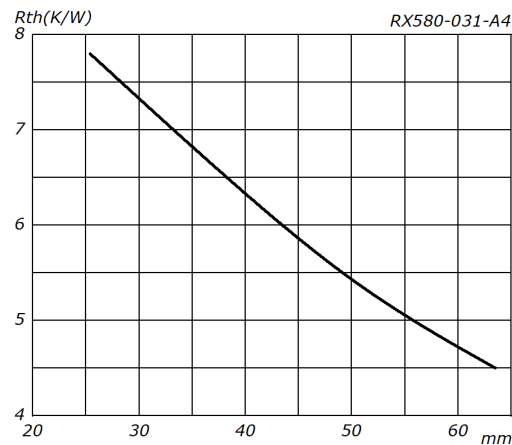
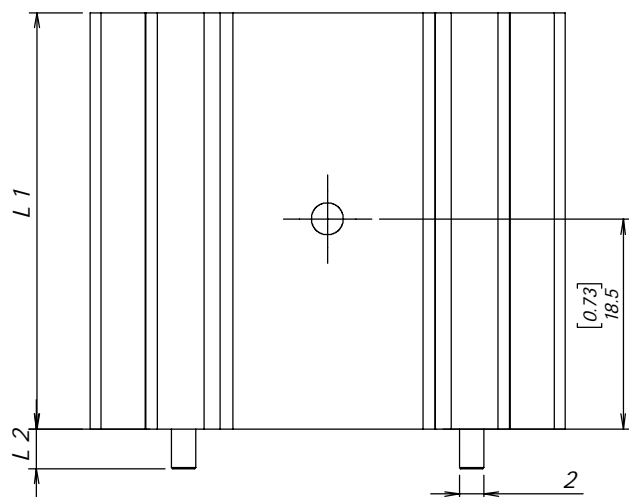
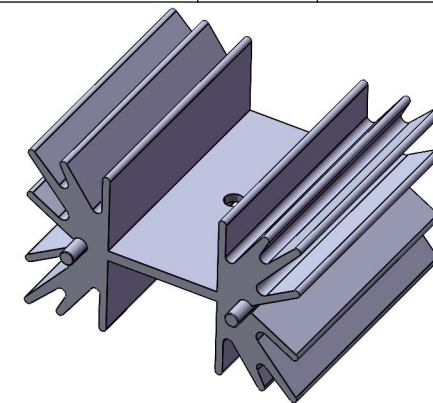
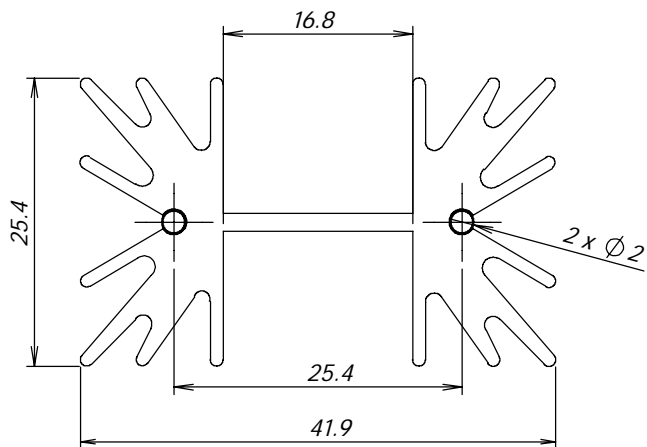

Flow Process List	
1	
2	
3	
4	
5	
6	
7	
8	

L1: : 25.4/38.1/50.8/63.5 mm

机械加工尺寸容许公差	
0 ~ 6	±0.1
6 ~ 30	±0.2
30 ~ 120	±0.3
120 ~ 400	±0.8
角度	±1°

Renxin Thermal Solutions
仁信精工实业有限公司
Renxin-Seiko Industry Co., Ltd
T:+86 769 8182 2159 F:+86 769 8182 2157
[Http://www.renxin-precision.com](http://www.renxin-precision.com)

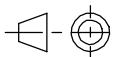
Description Heatsinkwithsolder pins PCB mounting for SOT 32/ TO 220/ TO 3 P				PN RX580-031-A4		Units:mm
CAT		Area	342.45 mm ²	Drw RX580-031-00		ISO2768-M
Design	LXG	Perimeter		Material AL6063-T5	Finish black anodize	
Approval		Scale	1:1	Ref	Weight(g)	34.036
Date	2016-08-03	Mount		Rev 1	Sheet	1 A4